

IFORS

NEWS

INTERNATIONAL FEDERATION OF OPERATIONAL RESEARCH SOCIETIES

FROM THE PRESIDENT

Héctor Cancela <cancela@fing.edu.uy>

Welcome to the March 2026 issue of the IFORS Newsletter!

We are very glad to give a warm welcome to the Sociedad Ecuatoriana de Matemáticas, SEDEM, as a new member society of IFORS! The colleagues from Ecuador presented their application, with the support of ALIO. As per our statutes, after consideration from IFORS AC, the matter was put to a vote by the member societies, which approved the application. As many of you know, IFORS was founded in 1959 by the UK, USA, and France. Since then, many countries have applied for membership; with Ecuador, we have now 56 member societies that participate and cooperate with IFORS objectives. The full list of national societies members of IFORS can be found on our web page, www.ifors.org. We encourage operational research practitioners in countries not represented to consider the possibility of organizing their societies and applying for membership; do not hesitate to contact us for support in this endeavor.



Last year, IFORS supported four events devoted to young scholars: the APORS Youth Forum in Hong Kong, the ORTASA school in Benin, the ELAVIO summer school on "Optimization and Artificial Intelligence in Agriculture" co-organized by ALIO and EURO in Lleida, Spain, and the Healthcare Operational Research graduate school organized in Montreal, Canada. These events included participation from the ALIO, APORS, EURO, and NORAM regional groupings as well as from the emerging AFROS region. We hope that we can support a similar number and diversity of events in 2026, and we also encourage the groups that may consider organizing such an event or school for this year or the following ones to get in touch with your national society and regional grouping, to propose your ideas, and take advantage of these opportunities.

As the President of IFORS, I would like to express my firm belief in the goals and the work of our federation, which is based on the mutual respect of our society members, representing the OR community of their countries, on the cooperation between societies, and on the exchange of information and best practices between scholars, practitioners and students. Our discipline and in general all science and technology areas develop when we share our knowledge and experiences, incorporating different perspectives and finding synergies. Young people are attracted to learn and work in our area when they feel welcomed by a community that works together to increase the efficacy and efficiency of companies and government, and to improve the quality of life for all persons on our planet. They are certainly inspired by the contributions our research makes to industrial and agricultural production, to healthcare, to education, to collective decision making, and to many other areas. In a moment where we see actors who posit a worldview based on self-interest, military and economic dominance, and hard frontiers, I hope that our federation and our societies will continue to work together, with the conviction that open cooperation and respect will lead to a better world. 🌍

WHAT'S INSIDE

- 1. From the President**
Héctor Cancela
- 2. From the Editor-in-Chief**
Sibel Alumur Alev
- 3. Call for Abstracts: IFORS 2026**
- 4. Finalists for the IFORS Prize for OR in Development**
- 5. GLOW: Global Leadership in OR for Women**
- 6. OR Impact**
BinPACKER – Using Operational Research to Optimise Packing for Air Transport
- 7. OR Tutorial**
Model Thinking for Everyday Life: Working Wonders with a Blank Sheet of Paper
- 8. Conferences**
Reports on conferences, webinars, summer schools and more
- 9. Book Review**
Interval Linear Programming and Extensions
- 10. Editorial Box**

FROM THE EDITOR IN CHIEF

Sibel Alumur Alev <sibel.alumur@uwaterloo.ca>

Welcome to the first issue of 2026!

I am delighted to begin this preface by sharing an announcement close to my heart. IFORS is officially launching **GLOW: Global Leadership in OR for Women!** This exciting initiative will serve as an umbrella organization to amplify regional programs such as WORMS (INFORMS Forum for Women in OR/MS) and WISDOM (EURO Forum for Women in Society Doing Operational Research and Management Science). We have prepared a video to mark the launch of GLOW, and you will also find a detailed article in this issue highlighting the goals and vision of this initiative.



In this issue, we feature an impact article on *BinPACKER – Using Operational Research to Optimise Packing for Air Transport*, written by Katrin Heßler, Timo Hintsch, Lukas Wienkamp, and brought to you by our section editors John Medhurst and John Ranyard. A fast 3D packing algorithm helps air freight operators maximise container utilisation, speed up loading, and reduce both costs and carbon emissions, demonstrating the real-world impact of OR in logistics.



▲ The launch of GLOW: Global Leadership in OR for Women by Maria Grazia Speranza, Janny Leung, Paula Carroll, and Rina Schneur (left to right).
[You can watch the video here.](#)

Our OR tutorial in this issue, curated by our section editor James Cochran, is titled “*Model Thinking for Everyday Life: Working Wonders with a Blank Sheet of Paper*”, written by Richard C. Larson. It shows how readers can tackle everyday and professional problems using simple tools, a pencil and blank paper, to apply conceptual and mathematical models.

The Conferences section brings you highlights from OR events around the world, showcasing the diverse experiences and insights of the community, thoughtfully compiled by Gerhard-Wilhelm Weber and Jinal Parikh.

This issue’s book review covers *Interval Linear Programming and Extensions* by Milan Hladík, providing a comprehensive and self-contained treatment of linear programming problems with interval data, curated by section editors Jinal Parikh and Gerhard-Wilhelm Weber.

Finally, if you haven’t already, don’t forget to submit your abstracts for the triennial **IFORS Conference**, taking place in the beautiful city of Vienna from July 12–17, 2026. The abstract submission deadline is March 15, 2026. Full details are available on the conference website: <https://ifors2026.at/home>.

I look forward to connecting with you again in the next issue!

Sincerely,
Sibel Alumur Alev
Editor-in-Chief 🌍

SUBSCRIBE TO THE IFORS NEWSLETTER

BY SCANNING THIS QR CODE >

<https://www.ifors.org/subscribe>



CALL FOR ABSTRACTS: IFORS 2026



We are delighted to invite you to take part in the IFORS 2026 Conference, to be held in Vienna, Austria, from July 12 to 17, 2026.

The International Federation of Operational Research Societies (IFORS; <https://www.ifors.org>) is a 60-year-old organization with currently 50 national member societies. One of its core activities is the IFORS Triennial Conferences (<https://www.ifors.org/ifors-triennial-conferences>).

The Program Committee, chaired by Andrés L. Medaglia (Universidad de los Andes, Colombia); and the Organizing Committee, led by Karl F. Doerner, Jan F. Ehmke and Richard F. Hartl (University of Vienna, Austria), are working closely together to create an unforgettable scientific experience.

The 24th IFORS conference offers the global Operational Research community an excellent opportunity to reunite in a vibrant city. Vienna's location in the heart of Europe, its excellent infrastructure, short distances, and exceptional quality of life are just some of the city's many strengths. In addition, Vienna impresses with its high standards of hospitality and an outstanding range of art and cultural events.

The University of Vienna, located in the city center and host of IFORS 2026, is the oldest university in the German-speaking world and the largest university in Austria. As a "universitas litterarum", it offers a broad range of subjects that promotes the development of innovative research areas and strengthens close connections between research fields.

We warmly welcome and encourage researchers, academics, practitioners, and students involved in Operational Research and related fields to submit their abstracts for review and contribute to this unique event!

Plenaries, keynotes, tutorials & special sessions

The scientific program includes outstanding plenaries, keynotes, and tutorials. In addition, excellent invited and contributed sessions, as well as a few special sessions and exciting social activities, will round out the program.

Plenary speakers

- Miguel Anjos (EURO Plenary Speaker; University of Edinburgh, UK)
- Harald Ponweiser (ÖBB-Austrian Railways, Austria)
- Katya Scheinberg (Georgia Institute of Technology, USA)
- Karen Smilowitz (Northwestern University, USA)

Keynote speakers

- Gabriele Eichfelder (Technische Universität Ilmenau, Germany)
- Radhika Kulkarni (SAS Institute Inc., NC, USA)
- Georgios Paschos (Amazon, Luxembourg)
- Beril Toktay (Georgia Institute of Technology, USA)
- Asgeir Tomasgard (Norwegian University of Science and Technology, Norway)
- Ming Xu (Tsinghua University, China)

Tutorial speakers

- David E. Bernal-Neira (Purdue University, USA)
- Katsuki Fujisawa (joint with Xun Shen and Pedro Galileo Romo) ([KF]: Tokyo Institute of Science, Japan; [XS]: Tokyo Institute of Agriculture and Technology, Tokyo Institute of Science, Japan); [PGR]: PGR, Inc.)
- Andrés Gómez (University of Southern California, USA)
- Rafael Martinelli (Pontifícia Universidade Católica do Rio de Janeiro, Brazil)
- Axel Parmentier (Institut Polytechnique de Paris, France)
- Georg Pflug (joint with Alois Pichler) (University of Vienna, Austria)
- Veronica Piccialli (Sapienza Università di Roma, Italy)
- Tal Raviv (Tel Aviv University, Israel)

Special issues (publications)

We are pleased to announce that several high-impact journals have agreed to publish special issues dedicated to high-quality research presented at the IFORS 2026 conference in Vienna. Detailed Call for Papers (CfPs) for each special issue will be published at <https://www.ifors2026.at/program/special-issues/>. Journals publishing special issues after the conference include International Transactions in Operational Research (Wiley), Central European Journal of Operations Research (Springer), Journal of Dynamics and Games (AIMS), Sustainability Analytics and Modeling (Elsevier), and OR Spectrum (Springer).

Abstract submission

- Abstracts must be submitted (in English) by 15 March 2026 at 23:59 CET.
- Abstracts should not exceed 600 characters.
- Abstracts should be submitted using the following link <https://www.euro-online.org/conf/ifors2026>.

Important dates

- December 1, 2025: Opening of abstract submissions
- March 15, 2026: Deadline for abstract submissions
- April 25, 2026: Early bird registration deadline
- May 1, 2026: Final registration deadline for authors

Registration

- Early student registration fee: € 460.00
- Standard student registration fee: € 520.00
- Early regular registration fee: € 670.00
- Late regular registration fee: € 860.00
- Guest/accompanying person fee: €150.00
- Conference banquet (optional extra): €150.00

The registration fee (regular and student) includes:

- Admission to all sessions and the exhibition
- Conference materials
- Coffee breaks throughout the conference
- Admission to the welcome reception on Sunday evening and the farewell party on Friday evening
- A half-day excursion

The guest/accompanying person fee only covers the half-day excursion, coffee breaks, welcome reception, farewell party, and the opening session

Student registration fees are available to anyone currently studying a Master or PhD. Uploading confirmation of valid Master/PhD studies is mandatory.

The conference banquet will take place at the Hilton Hotel on Thursday, July 16, 2026. Attendance is available for booking as part of your conference registration and costs € 150.00. Attendees are required to make their own transport arrangements to and from the banquet venue.

For more information, please see <https://www.ifors2026.at/registration/>.

Call for exhibitors

Parties interested in having a booth or exhibition area during the conference are kindly requested to contact the IFORS 2026 Conference Organizers at: ifors2026@univie.ac.at.

Andrés, Karl, Jan, and Richard

On behalf of the Program & Organizing Committees
IFORS 2026 Vienna
<https://ifors2026.at/home> 

SIX FINALISTS FOR THE IFORS PRIZE FOR OR IN DEVELOPMENT 2026

Awarded at every IFORS Triennial conference since 1987, the IFORS Prize for OR in Development aims to showcase and acknowledge high quality applications of OR in developing economy countries and economies in transition. Past winners and finalists include works that have improved health, wellness, education, disaster relief, public investments, and other issues in Africa, Asia, and Latin America.

In this 2026 edition of the competition, the entries have been evaluated in two stages. The first one required a short summary, and the second one required a full-length manuscript describing the work in more detail. The evaluation criteria included problem definition, creativity and appropriateness of approach, MS/OR/Analytics content, stress on developmental issues, extent of involvement of local researchers and impact.

We are pleased to announce the following six finalists of the IFORS Prize for OR in Development 2026:

- "Practical Application of Operational Research for Sustainable Agricultural Production and Waste Management in Vietnam", Trung Hieu Tran, Thu Ba T. Nguyen, Hoa Sen T. Le, Duc Chinh Phung, Hoai Chung Pham, Phuong Le Nguyen, Anh Phuong T. Huynh, Hoai An T. Le, Hoang Yen T. Be, Hai Van T. Dinh, Vatthanamixay Chansomphou, Hour Ix
- "Enhance: Balancing Multiple Solutions Through Enhanced Diet Optimization for Food Security", Melissa Françoise Koenen, Marleen Balvert, Hein Fleuren, Saskia de Pee, Claudia Damu, Cassidy Gasteiger, Marijn Markus,

René Flohil, Brent Kim

- "NIRSE-CL: Design, Monitoring, Real-World Effectiveness and Impact Assessment of Chile's Universal Immunization Strategy against RSV", Leonardo Basso, Felipe del Solar, Gonzalo Diaz, Marcel Goic, Ignasi Neira, Miguel O'Rya, Denis Saure, Charles Thraves, Juan Pablo Torres, Natalia Trigo, Amal Zgheib

- "Operations Research for National Food Security Operations in India", Shallu Bhasin, Nomes Bhojkumar Bolia, Elisabeth Faure, Ankit Sood, Shivam Sharma, Anita Karn, Mateshwari Mishra, Priya Jacob

- "Optimised planning for food banks with the incorporation of poverty metrics", Rhyan C. Rampazo, Daniela R. Cantane, Mariana O. Iamamoto, Dylan F. Jones

- "Prosecutor Heredia - Analytics meets Artificial Intelligence to efficiently combat Organized Crime", Carla Vairetti, Sebastián Maldonado, Fredy Troncoso, Richard Weber

The finalists will present their works during the 2026 IFORS Triennial conference in Vienna, Austria. Prizes of US\$4,000 and US\$2,000 await the first and runner-up winners, to be awarded during the conference's closing session on July 17, 2026.

The members of the panel of judges are: Maristela Oliveira dos Santos (ALIO), Guiying Yan (APORS), Tava Olsen (APORS), Shadi Sharif Azadeh (NORAM), Dmitry Krass (NORAM), Mario Guajardo (EURO and ALIO), Heletjé van Staden (Africa), Chair: Margaretha Gansterer (EURO) 

INTRODUCING GLOW: GLOBAL LEADERSHIP IN OR FOR WOMEN

by Yasmin Rios Solis, GLOW Communications Committee Chair

A New Initiative to Connect, Empower, and Promote Women in OR Worldwide

The [International Federation of Operational Research Societies](#) (IFORS) is proud to announce the launch of **Global Leadership in OR for Women (GLOW)**, officially established on September 18, 2025. This initiative represents a significant milestone in addressing gender equity within the Operational Research community and creating pathways for women to thrive in the field. The founders are the following amazing OR women: Paula Carroll, Janny Leung, Rina Schneur, and Grazia Speranza.



GLOW
Global Leadership in OR for Women

GLOW brings together OR professionals from across continents, including members from Asia, Europe, Africa, Latin America, and North America. This diverse international representation ensures that GLOW can address the unique challenges faced by women in OR worldwide while creating a strong global network of support and collaboration.

Join the Movement

GLOW represents an exciting opportunity to transform the landscape of Operational Research by ensuring that women have equal access to opportunities, recognition, and leadership roles. Whether you are an early-career researcher, an established professional, or an ally committed to gender equity, we invite you to be part of this important initiative.



▲ A screenshot from one of the GLOW meetings: Grazia Speranza, Paula Carroll, Sibel Alumur Alev, Janny Leung, Xujun Chen, Rina Schneur, Jana Ries, Yasmin Rios Solis, Di Nguyen, Rosa Gonzalez, Bolajoko N Dixon-Ogbechi, Chipo Zidana.

GLOW's mission is to connect, empower, and promote women in OR from around the globe by addressing common challenges, facilitating collaboration, and increasing visibility, recognition, and leadership opportunities for women in the profession.

GLOW is committed to advancing five strategic objectives:

- 1. Connect** different organizations and communities that share GLOW's mission
- 2. Network** by providing opportunities for women in OR to build professional relationships
- 3. Increase visibility** of women in OR at national and international levels
- 4. Promote equality** by ensuring equal opportunities and proportional representation of women at different career levels and in various professional roles
- 5. Activate research** at the intersection of gender equality and Operational Research

Join us at the [24th Conference of the International Federation of Operational Research Societies](#), 12-17 July 2026, Vienna, Austria, in the following events:

IFORS 2026 Inauguration: official launch of GLOW.

IFORS 2026 Social: a relaxed and fun GLOW reception.

IFORS 2026 Scientific: join the scientific GLOW program that highlights women's contributions.

For more information about GLOW and how to get involved, please visit the IFORS website or contact the GLOW committee through your OR region.

Together, we can illuminate the path forward for women in OR! 🌍

BinPACKER - USING OPERATIONAL RESEARCH TO OPTIMISE PACKING FOR AIR TRANSPORT



Katrin Heßler <katrin.hessler@dsv.com>, **Timo Hintsch** <timo.hintsch@dsv.com>, **Lukas Wienkamp** <lukas.wienkamp@dsv.com>

Based on the published article: A fast optimization approach for a complex, real-life 3D Multiple Bin Size Bin Packing Problem. Katrin Heßler, Timo Hintsch, Lukas Wienkamp. DSV. European Journal of Operational Research 327 (2025) 820-837.

Overview

The skies of the world are full of aircraft, so many that astonishingly there is not room enough in the world's airports for them all to be on the ground at the same time.

We are probably most familiar with the passenger services, transporting people from one part of the world to another for holidays, business trips and family reunions.

Less well known is the vast network of air freight services, responsible for moving urgent and high value cargoes. This includes many individual boxes and packets, of varying size, weight and importance, which altogether add up to enormous quantities of freight, travelling over our heads every day.

In the EU in 2024, 14.3 million tons of freight and mail were transported by air (Eurostat, 2025). The past 30 years have seen a steady increase in the amount of air freight, with the general spread of globalisation being mirrored by an increase in the amount of goods moved.

This volume of air freight also contributes to the carbon emissions due to air travel, a source of CO₂ for which low-carbon alternative energy sources are hard to find. Aviation also makes a significant contribution to effective emissions through the forcing effect of high-altitude contrails.

The Problem

Before transporting packages by air, it is normal for them to be loaded onto specialised air transport pallets or containers – referred to as Unit Load Devices or ULDs. These ULDs will then be transferred onto the transporting aircraft, ready to travel to their onward destination.

When transporting any kind of load by air it is important to make sure that it is securely stowed, both to ensure that the aircraft load remains balanced in flight and to minimise any possible damage to the contents.

When pallets are used as ULDs they must first be covered and lashed down, using nets or straps, which are securely fastened to the edge of the pallet. This adds the complication that items loaded onto the bottom layers of the pallet need to leave a margin around the outside to allow access to the fastening points.

To make best use of the available space in a cylindrical aircraft fuselage, ULD containers often have some bevelled faces which are oriented up, down or sideways to exploit available space in the bottom and sides of the fuselage (see Figure 1).

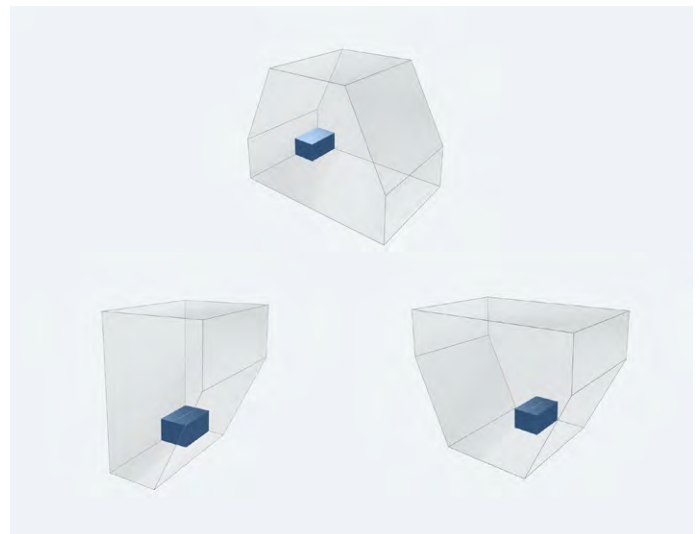

▲ Figure 1 – Examples of Fuselage-Fitting Containers

Whether ULDs are pallets or containers, it is important to load items in such a way as to maximise the proportion of the available volume that is utilised whilst respecting constraints on whether items can be rotated, tilted or stacked on top of one another.

This is complicated by the fact that in some cases padding will need to be inserted to fill gaps between the loaded items and provide extra support.

Finally, for stability both in the air and on the ground, it is important that packages are not put into ULDs in such a way that they are likely to topple or move whilst being transported, whilst also ensuring that the load is distributed evenly across the ULD.

Complicating all this is the fact that moving items by air is a continuous operation, with any delay due to time spent calculating optimum packing geometries likely to mean that the cargo will miss the departure time for its intended flight.

This means that any solution needs to be easily integrated into day-to-day operations, fast and reliable, with run-times in seconds rather than hours.

The Approach

This problem is one of a family of packing problems which are referred to as the three-dimensional multiple bin size bin packing problem or 3D-MBSBPP.

BinPACKER provides an automated solution for this kind of bin packing problem, optimised for day-to-day use in the logistics industry. BinPACKER uses a Randomised Greedy Search (RGS) algorithm, with several features that maximise the flexibility, speed and reliability of the solution.

The algorithm uses the concept of the 'Extreme Point', which identifies several candidate locations for the placement of each item. The first item is loaded in the far corner of the ULD and for each subsequent item a set of points is generated that cover the potential placement locations on the available surface. These points are then those that can be tested for feasibility for the placement of the next item (see Figure 2).

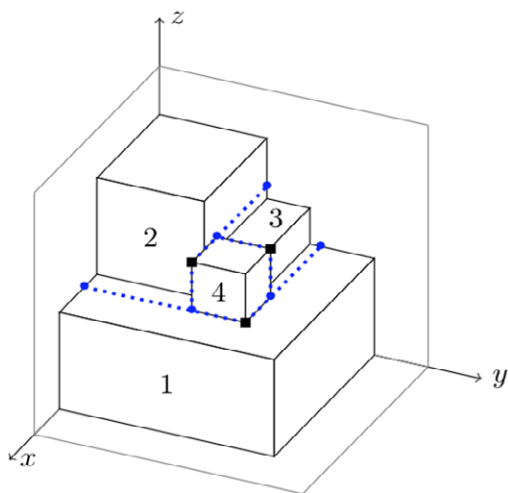

▲ Figure 2 – Generating Extreme Points (shown in Blue)

Unlike previous approaches using 'Extreme Points' such as Crainic et al (2008), the version used in the BinPACKER algorithm uses a greater number of extreme points and allows points to be moved to allow for efficient loading underneath bevelled ULD faces.

Generating a Solution

The items to be loaded are first grouped to allow sets of identical or almost identical items to be loaded together, then sorted according to five different schemes, based upon the size and stackability of the items, together with a randomisation parameter that varies this order. An additional random sorting scheme is used which can improve solutions in unusual situations.

The algorithm will work through all the different sorting schemes, loading the items in the selected order, with each newly loaded item being placed on the first extreme point that produces a feasible placement.

The most important innovative features of the BinPACKER approach are

1. The use of a pre-generated 3D grid to accelerate the testing of item loading positions. Instead of testing against all previously loaded items, only those items in the grid cells that touch the newly loaded item need to be evaluated. This is combined with the use of a 'First Fit' strategy, rather than relying on a complex merit function to compare different possible locations, which further speeds up solution creation.

2. Special item sorting strategies that combine layered and free packing, including trying to load items with the same height next to each other to create packing layers, allowing for maximum support and increasing placement options for items loaded on top.



Impact

In comparison, testing BinPACKER has demonstrated that it is faster and achieves at least comparable packing efficiency relative to existing algorithms.

The most important innovation is the use of the pre-generated 3D grid, which speeds up execution by up to 40% over previous approaches whilst utilisation can be improved by between 1 and 10%.

The speed of the tool means that most ULD problems can be solved in as little as 0.5 seconds, allowing the tool to be used for providing quotations and planning capacity as well as generating loading plans for operations.

Versions of the tool exist for Sea, Land and Air transport, as well as a logistics version for planning the packing of euro-pallets. The use of the tool has risen steadily, with more than 40,000 load plans being generated in 2025.

Trials of BinPACKER showed up to a 20% improvement in container utilisation, effectively saving every 5th container. Users have also praised the system's ease of use, clear 3D visuals of loading plans and speed.





With freight accounting for around 8% of world-wide greenhouse emissions (MIT Climate Portal, 2025), there is a clear role for OR in improving the efficiency of the system. BinPACKER is an example of how this can be done.

In recognition of this, the BinPACKER team were awarded the EURO Excellence in Practice Award for 2025.

So, next time you look up and see an aircraft flying overhead, it might just be carrying optimally packed freight rather than over-packed people.

References

Crainic T. G., Perboli G. & Tadei R. (2008) Extreme point-based heuristics for three-dimensional bin packing. *Inform Journal on Computing* 20 (3), 368-384

Eurostat (2025) [https://ec.europa.eu/eurostat/statistics-explained/index.php?title=Air freight transport statistics#Air freight and mail transport in the EU increased by 8.7.25 between 2023 and 2024](https://ec.europa.eu/eurostat/statistics-explained/index.php?title=Air_freight_transport_statistics#Air_freight_and_mail_transport_in_the_EU_increased_by_8.7.25_between_2023_and_2024) accessed Dec 2025

Heßler, K. Hintsch, T. & Wienkamp, L. (2025) A fast optimization approach for a complex, real-life 3D Multiple Bin Size Bin Packing Problem. *European Journal of Operational Research* 327, 820-837.

MIT Climate Portal (2025) <https://climate.mit.edu/explainers/freight-transportation> accessed Dec 2025

OR TUTORIAL

Section Editor: **James Cochran** <jjcochran@ua.edu>

Welcome to this *IFORS Newsletter Tutorial*! In this issue, we feature a tutorial by Richard C. Larson of the Massachusetts Institute of Technology on model thinking for everyday life. Dr. Larson provides an example from his book, *MODEL THINKING for Everyday Life: Working Wonders with a Blank Sheet of Paper*, that shows how we can demonstrate the importance, relevance, and beauty of the operations research mindset. You can read Jinal Parikh's and Gerhard-Wilhelm Weber's review of this book in the [December 2022 issue of IFORS News](#). I hope you enjoy reading this interesting tutorial.



I am *always* actively looking for potential topics and authors for the Tutorials Section. Please send me your suggestions for topics and let me know if you are interested in contributing a tutorial to this series - I will be happy to discuss your ideas with you. The target length is about 800-1200 words with figures, tables, and diagrams, and we can work with each author or team of authors (coauthored tutorials are welcome) to establish a publishing schedule that will fit their schedules. 🌐

MODEL THINKING FOR EVERYDAY LIFE WORKING WONDERS WITH A BLANK SHEET OF PAPER

Richard C. Larson <rclarson@mit.edu> Massachusetts Institute of Technology, IDSS – Institute for Data, Systems, and Society, Lexington, Massachusetts

Invest in yourself! As an IFORS member, try to learn something new each and every day! How? Think differently. See the world around you in terms of models, usually conceptual and sometimes mathematical. Become a true critical thinker! You'll begin to appreciate the "physics" of your world, thinking, understanding and appreciating. Maybe even being in awe of things you saw often but didn't really see. You'll share your new insights with family and friends, using the collaborative process of "discovery learning."

Did you know:

- In many logistical systems, you can "speed service" by deliberately inserting delays?

- In most service systems in which customers may have to wait for service, the duration of the wait is not the most important part of customer satisfaction?
- In choosing locations for wind turbines, the location with the highest average wind speed is not necessarily the one that will provide the most electrical energy?
- Simply moving certain chronically ill patients from one group to the next can increase the life expectancies of both groups?
- Of two baseball players, Julian and Brayton, Julian may have the higher batting average in each of two successive seasons, but—when the two seasons are combined—Brayton has the higher batting average?

- Most airline passengers may experience nearly full planes while airline management is worried about not reaching the break-even 50% load factor?
- About half of all marriages end in divorce, but only one out of eight existing marriages will end in divorce?

These questions are illustrative of ones that can be resolved with models, conceptual and mathematical. While we may not confront a bonified head-scratcher each day of our lives, we will undertake professional activities, consume news stories, read books, and engage in conversations that involve complex issues—all beyond our intuition. These can often be resolved by careful model thinking.

With so many hi-tech aids available to us, what technology do I recommend for addressing complex problems? **A sharpened pencil and many Blank Sheets of Paper!** Yes, I am retro! These tools, which I am sure you used as a 6-year-old in your 1st-grade class, allow us to move forward on many topics. A key motivation is our perception that much “learning” these days takes place on the computer. People often confuse a Google search with learning. They confuse dropping data into a “plug-and-chug” algorithm with learning. They have lost track of orders of magnitude, losing the ability to guesstimate the approximate answer to a problem. Faced with a new problem, people often lack the ability to frame and formulate it using basic principles. Some have called these problems a serious national (international?) syndrome of “Shallow Learning.” So, we urge moving ahead with all computers off, our only technology being a sharpened pencil and many Blank Sheets of Paper.

Model thinking has two important interpretations: (1) *thinking aided by models, both conceptual and mathematical*, and (2) *exemplary thinking—a type of thinking to be emulated*. You’ve heard the term “model citizen.” We can coin the phrase, “model thinker!”

Prerequisites. “*What background do I need to become a model thinker?*” The most important attribute is an open, inquiring mind and a willingness to concentrate and engage. Our emphasis is on problem framing and formulation, often employing ideas from applied mathematics and physics. A good background in high school mathematics is recommended, but no calculus! A past course in physics is nice, but not required.

Discovery-Learning with your Child. We learn from our children, and they from us.

“Mom, how come when it’s raining and we’re in the car, it always seems to rain faster on our windshield when you start driving, moving down the road?”

“Mom, how come when it’s raining and we’re in the car, it always seems to rain faster on our windshield when you start driving, moving down the road?”

You may have a correct answer in your pocket, ready to deliver. But this is a possible teaching moment for your child, to show them how to structure their thinking about daily situations they experience. It’s even better if you do not know the answer straight away, but must think it through in a “discovery-learning”

collaboration with your child. Result: Joint creation of a conceptual model that explains the situation. Research has shown that parents who involve their children in math and science early in life get them engaged and eager to learn more in school. A parent is a vitally important part of a child’s learning ecosystem.

With the help of an image, let’s go back to the child’s question about rain falling on a car windshield: If you think about this, you realize the question has a basis in



▲ Raindrops on a car windshield. Source: Koonsiri Boonnak, Shutterstock, <https://www.shutterstock.com/g/koonsiri>.

fact: You often have to increase the speed of the windshield wipers as you drive faster in a rainstorm. But how do you answer your daughter’s question? Our suggestion: Start with a reflective conversation with your child, to see if the two of you can come up with an approach that at least partially answers the question. Then, if necessary to work out more details, use a Blank Sheet of Paper, and work it out from basic principles. Forget formulaic approaches. It’s okay if you have no idea how to proceed, worrying that—in front of your children—you may appear to be unable to get to the explanation needed to answer their question. If that happens, it’s a good lesson to your children, that their interesting question is—momentarily—a mind puzzle. But, if you persevere, perhaps over hours or even days, you’ll eventually get there—and the discovery and thinking process you demonstrate to your children will be an invaluable lesson for them.

Looking at the car windshield, what about the rain apparently coming down harder as Mom drives the car away from an intersection? Suppose Mom goes from 0 miles per hour (mph) to 35 mph, and now the rain is definitely coming down harder on the windshield.

How should you think about this? How would you “model” this? Write down your thoughts on your 100% new Blank Sheet of

Paper! We are not asking for a full-blown physics model, just a few basic thoughts and ideas. When you are finished, see if your ideas match with our evolving mother-daughter conversation.

You, Mom, might start the conversation with a simple question to your child:

"Sally, do you think I have the power to increase the flow of falling rain simply by speeding up in the car?"

Sally might say,

"No, Mom, you can do so many things well, but controlling the rain is not one of them!"

So, Mom says,

"Then our conclusion about what we see on the windshield must be wrong in some way. What might that be?"

Mom's continuing conversation might go like this:

"Okay, when we are not moving, let's say that about 200 raindrops hit our windshield every second. But as we see with our own eyes, when we are moving, many more than 200 raindrops are hitting the windshield each second. Where are they coming from?"

Each now has her thinking cap on, and the clock is ticking ... tick, tick, tick ... Then suddenly,

"Mom, I've got it! As we speed up to 35 mph, our windshield not only still gets its 200 drops per second from rain falling straight down from above, but we also bump into raindrops in front of the car, drops that would not have hit our windshield if we were not moving. Now, at 35 mph, the drops we see on our windshield are both regular falling drops and new drops that we are crashing into! If we sped up to 60 mph, there would be even more! Wow!"

Mom:

"Sally, you've nailed it! I've never thought of that before. What we see is not what we get! Wonderful!"

This discussion has resolved the apparent illusion that Mom driving her car can affect how fast raindrops fall from the sky. This type of "discovery learning" is a great example of the adage:

**"Tell me and I forget.
Teach me and I remember.
Involve me and I learn."
-- Benjamin Franklin.**

The kinds of problems that we IFORS members encounter are usually not standard fare in math or science textbooks. They are not "turn-the-crank" problems. Other than answer-focused Google searches, computers are not much help. Our problems are often multi-step problems, and many of us in the age of instant Google searches have lost the ability—or perhaps the patience—to undertake multi-step problems. Some of these challenges may require you to think about them overnight. Again, in an age of instant gratification, a prolonged examination of the problem is not something many of us are used to. But dedicated critical thinkers, sketching their ideas out on paper, welcome such challenges!

The ideas above (and more) are discussed in my recent book, *MODEL THINKING For Everyday Life, How to make smarter decisions*. (Published by INFORMS, 2023) 🌐



IFORS 2026

<https://ifors2026.at/>

The 24th Conference of the International Federation of Operational Research Societies

12-17 July 2026, Vienna, Austria

Decision Support for a Sustainable World

Vienna is one of the leading meeting destinations in the world

The city's location in the heart of Europe, excellent infrastructure, short distances and exceptional 'livability' are only some of its many strengths. In addition, Vienna boasts high hospitality standards and an outstanding range of art and cultural events.

MEETING
DESTINATION
VIENNA
NOW ♦ TOGETHER





CONFERENCES

Section Editors:

Gerhard-Wilhelm Weber <gerhard.weber@put.poznan.pl>,
Jinal Parikh <jinal.parikh@ahduni.edu.in>



APORS YOUTH FORUM 2025 WAS SUCCESSFULLY HELD IN HONG KONG

Yukun Cheng <ykcheng@amss.ac.cn>, **Yang Deng** <yangdeng@tsinghua.edu.cn>,
Yong-Hong Kuo <yhkuo@hku.hk>, **Miao Song** <miao.song@polyu.edu.hk>,
Honglei Xu <H.Xu@curtin.edu.au>, **Yancheng Yuan** <yancheng.yuan@polyu.edu.hk>

The APORS Youth Forum 2025 was successfully held on 29 November 2025 at The Hong Kong Polytechnic University (PolyU). Jointly organized by APORS, Operational Research Society of Hong Kong (ORSHK), and PolyU's Department of Applied Mathematics (AMA) and Department of Logistics and Maritime Studies (LMS), the 2025 forum gathered over 120 young scholars and professors from 10 member societies across the Asia-Pacific region.

At the opening session, Associate Professor Honglei Xu, President of APORS, hoped that APORS use the Youth Forum as a starting point for long-term collaboration, stating that "today's exchange of ideas will shape tomorrow's innovations in OR." Professor Defeng Sun, head of the Department of Applied Mathematics of the Hong Kong Polytechnic University, Vice President of the Operations Research Society of China (ORSC), warmly welcomed all participants and highlighted the importance of collaboration and knowledge sharing among young researchers. He emphasized that the Youth Forum embodies PolyU's commitment to fostering interdisciplinary research and talent development in OR and Analytics.



▲ Prof. Yinyu Ye delivered the IFORS Tutorial Lecture.

From PhD to Professional

Following the IFORS Tutorial Lecture, the Forum held a panel discussion titled "From PhD to Professional." The panel was organized by Dr. Yancheng Yuan and invited distinguished guest professors including Professor Yinyu Ye, from Stanford University (Emeritus), Professor Yuhong Dai (President of ORSC and Vice President of IFORS) from the Chinese Academy of Sciences, Associate Professor Honglei Xu (President of APORS) from Curtin University, Professor Janny Leung (past President of IFORS) from the University of Macau; and Professor Yukun Cheng (Deputy Secretary-General of ORSC) from Jiangnan University. The panelists engaged in in-depth exchanges on topics such as research accumulation, cross-institutional collaboration, and diversified career development. The discussion offered practical guidance on building a strong methodological foundation, engaging in cross-institutional collaboration, and exploring diverse OR career paths in academia, industry, and government.

Bright Future across the Asia-Pacific OR Community

This year, the APORS Best Paper Award competition attracted 13 high-quality submissions from young researchers across the region. After a rigorous review process, 6 papers were selected to receive the APORS Best Paper Awards, honored for their outstanding originality, methodological rigor, and relevance to practical applications.

In the afternoon, 12 thematic sessions covered topics such as optimization theory, game theory, data-driven logistics, stochastic control, and intelligent transportation. Presentations demonstrated how young researchers are combining OR, AI, and data science to solve pressing societal and industrial problems. Additionally, participants engaged in extensive group discussions on the future development of APORS.



▲ Participants at the lecture room of the PolyU.

OR's time in the AI era

This event was sponsored by the IFORS Tutorial Lecturers program in which outstanding scholars are supported by the IFORS to give the fundamentals of emerging OR technologies, application areas or teaching approaches at important regional grouping conferences. For this event, Professor Yinyu Ye from Stanford University (Emeritus) delivered a presentation titled "Mathematical Optimization and Operations Research for AI." He shared his insights on how OR enhances new AI computing tools and how GPUs accelerate optimization algorithms. Professor Ye concluded with an encouraging message to young OR scholars: "It is our (OR scholars') time." The tutorial lecture was chaired by Professor Miao Song from PolyU of HK.



▲ Panel Discussion.

Thanks to the generous support of *IFORS Travel Fellowships*, 9 undergraduate/postgraduate students and early-career researchers from Australia, India, Indonesia, Malaysia, Singapore, Taiwan, Province of China, and the United States were able to attend the event. At the same time, *APORS* extends its gratitude to Springer Nature for their support of the Best Paper Award.



▲ Group photo of the winners and runner-ups.

The *Organizing Committee* extends its gratitude to all participants, reviewers, and volunteers whose contributions made the event a success. In the future, the *APORS Youth Forum* will continue to promote interdisciplinary collaboration, methodological innovation, and real-world impact across the *Asia-Pacific OR Community*.

Reflections from Awardees of the *IFORS Travel Fellowship* to the *APORS Youth Forum 2025*

All 9 awardees found the *APORS Youth Forum 2025* a stimulating and rewarding experience. Especially, they found the talk by Prof. Yinyu YE, *IFORS Tutorial Lecturer*, very inspiring. Below are some reflections - and suggestions - from the awardees:

Ruicheng AO (USA): "All presenters were exceptionally well-prepared, which contributed to the high quality of the discussions."

Zihao LI (Singapore): "The Forum also provided a great opportunity to meet young researchers from across Asia, exchange ideas, and build new academic connections."

Tian TIAN (Malaysia): "This experience ... strengthened my motivation to further integrate theoretical research with real-world industry challenges."

Aneng HE (Malaysia): "The warm interactions, constructive feedback, and vibrant discussions helped me appreciate how closely connected the OR community is, both within Asia and internationally. *APORS* or *IFORS* might consider hosting ... thematic forums to promote OR applications in emerging interdisciplinary social science domains, including education, health policy, and social equity analytics."

Du CHEN (Singapore): "The tutorial by Prof. Yinyu Ye greatly broadened my perspective on OR in ways I had never expected. The Forum [allowed me to] connect with others who share similar passions, and return home with new ideas and renewed confidence in my academic journey."

Abhay SOBHANAN (India): "The Forum welcome a few international participants, which added valuable perspective. However, moving forward, I believe further efforts could significantly enhance the forum's reach, making it more globally diverse in terms of both researcher representation and the breadth of research directions discussed."

Bowen ZHAO (Australia): "The panel discussion on the choice between academic and industry ... [was] particularly valuable for me as I'm also partially working within the industry closely related to my research."

Ruey-An SHIU (Taiwan, Province of China): "The *APORS Youth Forum* created a friendly and energetic environment where I could meet many young researchers who share similar interests and challenges."

Prof. Dr. Janny LEUNG 

SPRING SCHOOL AND WORKSHOP VARIATIONAL ANALYSIS AND OPTIMIZATION 2025 SUCCESSFULLY HELD IN HANOI, VIETNAM

Dong Yen Nguyen <ndyen@math.ac.vn>, Zhou Wei <weizhou@hbu.edu.cn>

Spring School and the International Workshop "Variational Analysis and Optimization 2025" (ICOVAO-2025) was held on March 10-15 2025, in Hanoi, Vietnam. Jointly organized and co-sponsored by the Institute for Advanced Study in Mathematics, Hanoi National University of Education 2, the Institute of Mathematics, Vietnam Academy of Science and Technology, Vingroup Innovation Foundation (VINIF), and the International Center for Mathematics Research and Training, *ICOVAO-2025* created a broad international forum to present the fundamental principles of variational analysis and optimization theory, to exchange new results and new ideas in these fields. There were 59 invited

speakers confirmed from 17 countries, many of whom are internationally renowned scholars (<https://viasm.edu.vn/hdkh/ICOVAO-2025>).

The *Spring School* and the *Workshop* were organized in a combination of in-person and online formats. There were 199 delegates registered to attend in person and online, of which 108 delegates attended in person.

After 6 days of exciting work, the *Spring School* and the *Workshop on Variational Analysis and Optimization 2025* at the Institute for Advanced Study in Mathematics - VIASM ended successfully.>>



▲ Participants and conference staff.

>> There were 16 lectures at the *Spring School*, 2 public lectures on the occasion of *Mathematics Day* on March 14, 40 invited talks, and 10 contributed talks by speakers from 17 countries.

During March 11-14, *ICOVAO-2025* Workshop featured 10 plenary talks, delivered by *Juan Enrique Martinez-Legaz* (Autonomous University of Barcelona, Spain), *Christiane Tammer* (Martin-Luther University Halle, Germany), *Michel Théra* (University of Limoges, France), *Yu-Hong Dai* (Chinese Academy of Sciences, China), *Boris S. Mordukhovich* (Wayne State University, USA), *Geovani Grapiglia* (UCL, Louvain-La-Neuve, Belgium), *Abderrahim Jourani* (Université de Bourgogne, Dijon, France), *Sebastian Pokutta* (Zuse Institute Berlin, Germany), *Poom Kumam* (King Mongkut's University of Technology Thonburi, Thailand) and *Laurent Condat* (King Abdullah University of Sciences and Technology, Saudi Arabia).

Since March 14 is "Pi Day" ($\pi = 3.14\dots$), 2 public lectures, delivered by *Boris S. Mordukhovich* (Wayne State University,

USA) and *Sebastian Pokutta* (Zuse Institute Berlin, Germany), were given for a large audience, including the participants of the Workshop and the School.

ICOVAO-2025 was a great success with 199 delegates registering to attend in person and online, of which 108 delegates attended in person. The lectures and reports cover variational analysis and applications to optimization, control, equilibria, stability, machine learning, statistics, and practical models of science and technology.

The organization of *ICOVAO-2025* was also carried out carefully, thoughtfully, ensuring safety according to regulations.



▲ Invited speakers in plenary talks.

ICOVAO-2025 in Hanoi, Vietnam, was endorsed by *IFORS* through the participation of *IFORS* Vice President *Yu-Hong Dai*.

Cordial thanks to dear *Prof. Yu-Hong Dai* for his communication support that made this report possible. 🌐

ORTASA–DSS 2025 CELEBRATED IN BENIN, WITH THE FOUNDING EVENT OF THE OPERATIONS RESEARCH SOCIETY OF WEST AFRICA

Jules Dégila <jules.degila@imsp-uac.org>, **Ida Tognissè** <ida.tognisse@imsp-uac.org>

The 3rd *Regional School in Operations Research (ORTASA)* was held from 10 to 13 November 2025 at the *Institute of Mathematics and Physics (IMSP), University of Abomey-Calavi*, Benin, jointly organised with the 5th *Data Science School (DSS)*. The event aimed to strengthen capacity building, advanced training, and research exchange in *Operations Research (OR)*, *Data Science*, and *Artificial Intelligence*, with a particular focus on African challenges (visit <https://www.imsp-benin.com/home/> for more about the institution).

The scientific programme comprised 17 sessions, including 2 plenary sessions, 9 tutorials, and 6 thematic parallel sessions. *ORTASA-DSS 2025* brought together over 50 speakers and contributing authors from more than 10 countries. *Participation* was strongly anchored in West Africa, notably Nigeria, Benin, and Burkina Faso, and complemented by international contributions from Canada, France, Germany, South Africa, Iraq, Senegal, Togo, and Mauritania, some of which were made remotely. *Topics* covered included artificial intelligence, optimisation and decision-making, health and epidemiological modelling, energy systems, transport and telecommunications, and



▲ Cross-section of participants at the 3rd *ORTASA 2025* School.

data-driven education, highlighting the interdisciplinary nature of modern *OR* and its relevance to sustainable development.

A major highlight of the event was the initial physical meeting and inaugural launch of the *Operations Research Society of West Africa (ORSWA)*, held on 12 November 2025 during the school.>>

>> This marked the first in-person assembly of *OR professionals* in the region following a series of virtual preparatory meetings conducted between 2022 and 2025. Delegates from nine West African countries (Benin, Burkina Faso, Côte d'Ivoire, Ghana, Mali, Mauritania, Nigeria, Senegal, and Togo) unanimously adopted the *ORSWA Constitution* and elected the pioneer executive council, thereby providing the society with a formal legal and operational framework. The launch of *ORSWA* represents a significant step toward strengthening regional cooperation, professional networking, and *OR's* visibility in West Africa.



▲ Participants at the Administrative Building of *IMSP*.

The organisers gratefully acknowledge the support of the *International Federation of Operational Research Societies (IFORS)*, the *Modelling and Simulation Hub, Africa (MASHA)* at the University of Cape Town, the *African Centre of Excellence in Mathematical Sciences and Applications (CEA-SMIA)*, and the *Institute of Operational Research and Management*

Science of Nigeria (IORMS).

Particular appreciation is extended to *IORMS* for its strong participation, led by its national president and several executive members, which significantly contributed to the scientific discussions and regional engagement. These collective efforts underscore a shared commitment to advancing *Operations Research and Data Science* for societal impact in Africa.

For pictures and other social events during the event see: <https://drive.google.com/drive/folders/1pTUFhAKECSEFb3Q2CPqQgouK26yJNBPr?usp=sharing>.

The *ORTASA 2025 School* in Benin was supported through *IFORS* sponsorship.

Cordial thanks to dear **Prof. Adewoye Olabode**, for his communication support that made this report possible 🌍

ICAHS 2025 IN HAMAMET, TUNISIA ADVANCING HEALTHCARE SYSTEMS THROUGH INTERDISCIPLINARY APPROACHES

Sondes Hammami <sondes.hammami@enicar.ucar.tn>, **Imen Mejri** <imen.mejri@enit.utm.tn>, **Najla Aissaoui** <najla.aissaoui@enicar.ucar.tn>, **Safa Bhar Layeb** <safa.layeb@mines-albi.fr>

The *International Conference on Advanced Healthcare Systems (ICAHS 2025)*, hosted by *AWG Healthcare Systems* and funded by *IFORS*, was held on 5-6 December 2025 in Hammamet, Tunisia (<https://sites.google.com/view/icahs2025/home>). The inaugural edition was offered in a hybrid format, allowing participants to attend either onsite or online, and successfully brought together researchers, practitioners, and policymakers from 12 countries.

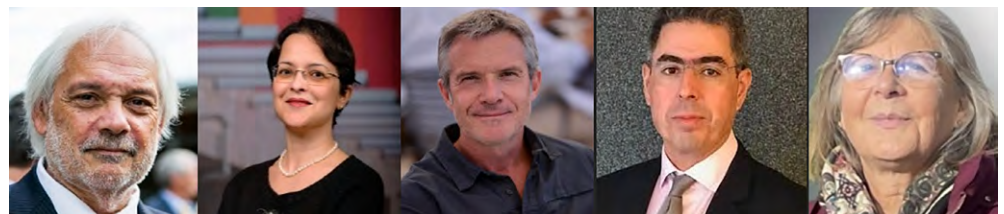

▲ Some of *ICAHS 2025 Keynote Speakers* (left to right): *Prof. Philippe Wieser* (EPFL, Switzerland), *Prof. Monia Rezik* (FSA, Canada), *Prof. Franck Fontanili* (IMT, France), *Prof. Fraouk Yalaoui* (UTT, France), *Prof. Meriem Jaidane* (ENIT, Tunisia).

five *keynote speakers* from Switzerland, Canada, France, and Tunisia, who shared insights into emerging research and challenges in healthcare systems.

ICAHS 2025 explored healthcare systems through an interdisciplinary lens, bringing together expertise from industrial engineering, artificial intelligence, biomedical engineering, architecture, and economics. The conference emphasized that integrating these diverse disciplines is essential for innovating healthcare solutions, improving operational efficiency, patient care, and the sustainability of healthcare systems.

A special *panel session* brought together three distinguished Tunisian researchers, engaging in a stimulating discussion on the intersections of architecture, artificial intelligence, and healthcare, highlighting the value of interdisciplinary collaboration in addressing complex healthcare challenges.

The conference also included 18 *parallel sessions*, covering themes such as:

The conference received 142 paper submissions, of which 105 were accepted for presentation. All accepted papers will be submitted to *IEEE Xplore*. Selected best papers will be invited to submit extended versions for a special issue titled "*Optimization, Management, and Computational Intelligence in Healthcare Systems*" in the *Journal of Management Science and Information Technology*. The program featured

Assessing Healthcare System Performance via Quantitative and Economic Techniques, Explainable and Trustworthy AI for Advanced Healthcare Systems, Decision Support Tools for Medical Diagnosis and Therapeutic Decision-Making, Architectural Design for Well-Being and Human Health, AI and Digital Technologies for Healthcare Marketing Strategy: Innovation and Social Acceptability.



▲ The ICAHS 2025 Group Picture.

Additional topics included biomedical engineering, mechatronics, digital health technologies, and smart and sustainable healthcare operations, demonstrating how the integration of multiple disciplines can enhance patient outcomes, operational efficiency, and system sustainability.

ICAHS 2025 fostered global collaboration, bringing together participants from Tunisia, France, Belgium, India, China, Saudi Arabia, Italy, USA, Japan, the United Kingdom, Canada, and Morocco. The diversity of contributions showcased the crucial role of interdisciplinary approaches

in advancing healthcare systems research and practice, offering actionable solutions to complex challenges in healthcare operations and management.

The inaugural ICAHS established a vibrant platform for interdisciplinary exchange in healthcare systems. By combining cutting-edge research, practical applications, and global perspectives, the conference underscored the importance of collaboration across disciplines to drive innovation, improve healthcare delivery, and shape sustainable healthcare systems worldwide. 🌐

DECISION SCIENCE BY THE LAKE – THE SOR 25 EXPERIENCE IN SLOVENIA

Lidija Zadnik Stirn <lidija.zadnik@bf.uni-lj.si>, Samo Drobne <samo.drobne@fgg.uni-lj.si>

The 18th International Symposium on Operations Research in Slovenia (SOR'25, <https://sor.fov.um.si>) took place from 24-26 September 2025 in Bled. It was organised by the Slovenian Society INFORMATIKA - Section for Operations Research (SSI-SOR), in cooperation with the University of Maribor, Faculty of Organisational Sciences (UM FOV), and Rudolfovo - Science & Technology Centre Novo mesto.

The biennial event brought together the OR community for scientific exchange and networking. Five plenary speakers - Tamás Terlaky, Sanja Petrović, Josip Arnerić, Milica Maričić, and Drago Bokal - presented advances in optimisation, decision analytics, and applications of OR methods to real-world problems.

The scientific programme featured over 100 presentations by more than 200 authors from 20+ countries, covering topics such as optimisation, multicriteria decision-making, statistics, logistics, financial modelling, human-resource planning, and computing applications.

All accepted papers and extended abstracts were published



▲ Group photo on the first day of the symposium in front of the entrance to the Astoria Hotel, Bled.

in the official *SOR'25 Proceedings*, edited by Samo Drobne, Lidija Zadnik Stirn, Mirjana Kljajić Borštnar, Janez Povh, and Janez Žerovnik. The open-access proceedings are indexed in Mathematical Reviews, Zentralblatt, and INSPEC and available [here](#).

SOR'25 successfully strengthened international cooperation and reaffirmed the importance of OR in addressing complex decision-making challenges across academia, industry, and public administration.

More highlights and photos are available at <https://sor.fov.um.si/sor25-highlights/>. 🌐



▲ Performance by a local folk dance group (left) and quiz winners (right).



10TH INTERNATIONAL SYMPOSIUM AND 32ND NATIONAL CONFERENCE ON OR – HELORS 2025 IN PICTURESQUE CHANIA, GREECE

Eleftherios Siskos <esiskos@tuc.gr>, **Michalis Doumpos** <mdoumpos@tuc.gr>, **Constantin Zopounidis** <kzopounidis@tuc.gr> **Nikolaos Matsatsinis** <nmatsatsinis@tuc.gr> (Chairs of HELORS 2025)

HELORS 2025 was conducted from November 20th to November 22nd, 2025, at the Technical University of Crete, in Chania, Greece. This year, the conference was co-organized by the *Hellenic Operational Research Society*, the Region of Crete, and the Municipality of Chania, with a focus on the theme “Operational Research, Artificial Intelligence, and Innovation for the Energy Transition”. The conference brought together researchers, industry leaders, and students, promoting a vibrant exchange of ideas and insights.



▲ Group photo of HELORS 2025.

Key highlights included 52 scientific presentations from 9 countries around the globe. The conference featured two keynote speeches: from Prof. Emer. John Psarras (National Technical University of Athens) on OR tools facilitating the Energy Transition, and from Prof. Emer. Yannis Siskos (University of Piraeus) on the *MUSA method and its applications*. A special session was dedicated to the memory and contributions of Prof.



▲ HELORS Gold Medal awarded to Prof. Emer. J. Psarras (left) and Prof. E. Grigoroudis (right).

Evangelos Grigoroudis, honoring his influential scientific work. Additionally, the prestigious *HELORS Gold Medal* was awarded to Prof. John Psarras for his outstanding contributions to the field of OR, and posthumously to Prof. Evangelos Grigoroudis.

The conference publications include the Book of Abstracts, available [HERE](#), the book of *Conference Proceedings* (in progress), and two upcoming Special Issues in the scientific journals of

Operational Research: An International Journal (ORIJ; IF 2024: 2.7), and *Inter-national Journal of Decision Support Systems (IJDS)*. Finally, selected research works will be published in a paper collection in Springer’s “*Lecture Notes in Operations Research*” book series.

A heartfelt thank you to all our participants, keynote speakers, and the dedicated organizing team whose hard work made this event a success. Special thanks also go to the Region of Crete and the Municipality of Chania for their support. 🌍

NORS 2025 AN INSPIRING GATHERING OF OR RESEARCHERS IN KRISTIANSUND, NORWAY

Arild Hoff <arild.hoff@himolde.no>

The *Fourth Annual Conference of the Norwegian Operations Research Society* was organized by the Faculty of Logistics at *Molde University College*, November 25-26, 2025. The conference venue was the new *Campus Kristiansund*, opened just one year ago.

The *NORS Conference* aims to be a meeting place for operations researchers for exchanging ideas and presenting ongoing research, and for discussing industrial challenges, modelling approaches and/or solution methods. In particular, PhD students within the field of *operational research (OR)* are encouraged to present their work and develop their professional network.

The current version of the conference gathered 58 researchers mainly from Norwegian universities, but also representing universities and institutions from Denmark, Hungary, Belgium, France, India, and Singapore. A special thought was given to the late professor *Arne Løkketangen*, who was the founder of the Optimization Research Group at Molde University College and one of the pioneers of OR and metaheuristic research in Norway.

The conference contained two plenaries and a total of 42 additional presentations given in twelve different parallel sessions grouped on diverse subjects such as OR in Energy Logistics, OR in Healthcare, >>



▲ Conference chair Arild Hoff opening the conference and presenting the keynote speaker Kenneth Sörensen. (Photo: A. Waagbø)

>> OR with Electrical Vehicles, Maritime and Aquaculture, Maritime Shipping, Stochastic Optimization, Routing and Delivery problems, Methodological Contributions, AI Applications, and Innovative Analytics and Applications.

The first plenary talk was given by Professor Kenneth Sörensen from the University of Antwerp. His talk was titled “Metaheuristics - Towards an Empirical Science” and gave a critical viewpoint on the direction of the research on metaheuristics. In the final plenary talk, Professor Lars Magnus Hvattum spoke about how OR could be used as support for football clubs, for example, by creating rating models for clubs as well as for individual players or a combination of players.

In addition to the scientific program, there was allocated

time for lunch and coffee breaks, and a conference dinner, where the participants could interact in a more informal way with the other researchers, and such maintaining and extending their professional and personal networks.

A great thanks to all participants and all enthusiastic members of the organization committee who contributed to a successful conference!

Details about the event can be found on <https://www.himolde.no/nors2025> and more information about NORS can be found on their website <https://www.nors-online.no/>.

Cordial thanks to dear Prof. Peter Schütz for his communication support that made this report possible. 🌐



▲ Group photo of NORS 2025. (Photo: A. Waagbø)

FORS AUTUMN SEMINAR CELEBRATED IN AALTO, FINLAND, HIGHLIGHTING STRATEGIC DECISION-MAKING AND OR IMPACT – EEVA VILKKUMAA NAMED OR PERSON OF 2025

Jussi Leppinen <sihteeri@operaatiotutkimus.fi>

The Finnish Operations Research Society (FORS) held its autumn seminar on November 6th under the overarching theme “OR supporting strategic decision-making.” The event focused on how data, modelling, and analytics can support strategic decision-making in a world shaped by rapid advances in artificial intelligence and shifting geopolitical conditions. The seminar brought together board members and active participants, creating an approachable, engaging atmosphere with familiar faces and high-quality presentations.

The seminar opened with a talk by Associate Professor Eeva Vilkkumaa from Aalto University School of Business. Her presentation, “Scenario-Based Decision Analysis for Strengthening Strategic Resilience,” illustrated how operations research tools help organisations prepare for uncertain futures. As uncertainty grows, so does the number of plausible scenarios, and Vilkkumaa highlighted how carefully selected scenarios and well-designed decision models can support expert judgement even when the future

cannot be quantified precisely. Her presentation showcased the tangible impact of OR in enhancing long-term strategic preparedness.

Next, Jussi Leppinen from Aalto University’s Systems Analysis Laboratory presented “A Staged Decision Process to Support the Development of AI Solutions for Predictive Maintenance.” His talk demonstrated how OR methods help structure complex development processes when reliable information is not yet available. By enabling organisations to make informed decisions at each stage, from early candidate selection to exploratory testing, staged processes support strategic alignment and effective resource use. The discussion that followed emphasised that despite common terminology, predictive maintenance often relies not on “AI” in the popular sense but on rigorous, data-driven machine learning, again reflecting the grounded, practical nature of OR impact.



▲ Eeva Vilkkumaa and the President of FORS, Olli Herrala.

The final presentation was given by *Henna Laasonen*, Head of the VATT Data Room, on “*Real-Time Microdata Analysis Supporting the Finnish Government.*” She described how timely data and analysis guide legislative work and policymaking. The examples she presented illustrated how integrating multiple data sources can reveal societal patterns and inform decisions with real-world consequences, underscoring once again how operations research and analytics directly shape public-sector impact.

During the event, FORS also announced *Eeva Viikkumaa* as the 2025 OR Person of the Year. The award recognises individuals whose work has significantly advanced the applications or theory of operations research, reflecting the society’s commitment to highlighting impactful contributions. Viikkumaa, who completed her doctorate in 2014, has made significant scholarly advances in scenario

analysis and portfolio decision analysis, with publications in leading journals such as *Operations Research*, *Management Science*, and *EJOR*.

Beyond her research achievements, she has had a lasting impact on the *Finnish OR* community through award-winning teaching, eight years of service on the FORS board, and her role as Vice Chair of the organising committee for *EURO 2022*, the largest OR conference ever held in Finland. Her career exemplifies how OR can influence both theory and practice, making a meaningful difference across sectors.

After the presentations, participants continued discussions over dinner, further exchanging ideas on how OR contributes to organizational decision-making and societal development. 🌐

THE REVENUE MANAGEMENT & PRICING COMMUNITY COMES TOGETHER IN LUXEMBOURG

Christiane Barz <Christiane.Barz@business.uzh.ch>, Benny Mantin <Benny.Mantin@uni.lu>

The 6th Biennial Meeting of the [EURO Working Group on Revenue Management & Pricing](#) (EWG-RMP) was held on 4 December 2025 at the University of Luxembourg, Campus Kirchberg. The meeting brought together researchers and practitioners active in revenue management, pricing, and related areas, continuing the tradition of the working group as a forum for scientific exchange at the interface of theory, data, and practice.



▲ Group Photo.

Scientific Program: The one-day scientific program comprised more than twenty presentations, including two keynote lectures, which provided focal points for the meeting. [Ilan Lobel \(New York University Stern School of Business\)](#) presented recent joint work on “*Randomly Wrong Signals: Bayesian Auction Design with ML Predictions*”. The keynote addressed a Bayesian mechanism design problem in which a seller seeks to maximize revenue using predictions of buyers’ valuations generated by machine learning models that may be imperfect. The proposed framework explicitly distinguishes between informative signals and “hallucinations,” i.e., predictions uncorrelated with true valuations. Lobel presented a characterization of the optimal auction in this setting. In the single-buyer case, the optimal policy reduces to three intuitive pricing actions (ignoring, following, or capping the signal) offering clear guidance on how unreliable predictions should be incorporated into revenue-maximizing mechanisms.

[Guillaume Roels \(INSEAD\)](#) delivered a keynote entitled *Optimizing Service Encounters: A Co-Productive, Experiential, and People-Centric Approach*, drawing on the conceptual framework developed in his recent book *Optimizing Service Encounters: A Co-Productive, Experiential, and People-Centric Approach*. The talk shifted attention from traditional revenue management to the optimization of service encounters, defined as the interfaces between customers, employees, and service organizations where most value creation in services occurs. Roels discussed three central levers for optimizing such encounters in a digital environment: leveraging co-production in service design, shaping customer experiences, and fostering employee engagement.

The contributed sessions reflected the methodological diversity of the field, spanning dynamic pricing, capacity allocation and network revenue management, assortment and choice modeling, empirical pricing analysis, and applications in mobility systems, retail, and online marketplaces. Several talks were motivated by concrete industry problems, relied on proprietary or large-scale operational data, or addressed decision-making challenges faced by firms in transportation, shared mobility, retail, and digital platforms. This mix of methodological rigor and practical relevance underscored the applied orientation of the EWG-RMP community.

Social Program: In addition to the scientific exchange, the meeting served as an important occasion for discussing the future direction of the working group. Draft governance guidelines for the *EURO Working Group on Revenue Management & Pricing* were presented and discussed, and participants were informed about upcoming board elections scheduled for January 2026.

The event was preceded by an informal get-together at the magical *Luxembourg Christmas market* on the evening before the meeting and concluded with a conference dinner, allowing for ample networking opportunities.

Acknowledgement: The 6th EWG-RMP Meeting benefited from the kind contribution of the [EURO association](#) and additional funding from the [University of Luxembourg’s Department of Economics and Management](#) as well as the [Luxembourg Centre for Logistics and Supply Chain Management \(LCL\)](#), which made it possible to accommodate PhD students for free while charging minimal registration fees from all other attendees. 🌐

ADVANCES IN PREFERENCE HANDLING: M-PREF 2025 IN BOLOGNA, ITALY – A STRONG PROGRAM WITH FRESH IDEAS

Ulrich Junker <ulrich.junker@uli-research.com>, Khaled Belahcène <khaled.belahcene@centralesupelec.fr>, Nimrod Talmon <nimrodtalmon77@gmail.com>

Bologna, the city with the oldest European university, welcomed more than 2000 researchers from 58 countries in late October 2025, who participated in the 28th *European Conference on Artificial Intelligence*. The 16th *Multidisciplinary Workshop on Advances in Preference Handling* has been held as part of the workshop program of this conference on Saturday, 25, 2025. It is part of a workshop series, coordinated by the *EURO Working Group on Preference Handling*, which explores computational methods for learning, representing, aggregating, and applying preferences. Its 16th edition was organized by Ulrich Junker, Khaled Belahcène, and Nimrod Talmon. The workshop attracted between 20 and 24 participants.



▲ M-PREF 2025 participants.

We could offer a strong program with two prominent *invited speakers* who presented their newest ideas. Ulle Endriss (University of Amsterdam) examined the nature of axioms in social choice theory and gave a meta-theory to describe their meaning, logical strength, and dimensionality. Based on this meta-theory, he could formalize some classifications of voting rules introduced by Peter Fishburn. Edith Elkind (Northwestern University) addressed the problem of polarization in social choice and introduced voting rules

for choosing interlacing committees that maximize interconnections between voters. She analyzed the complexity of these voting rules and their impact on other representation objectives such as excellence, diversity, and proportionality.

In addition, the workshop featured 11 *technical presentations* and allowed young PhD students to present fresh ideas on topics such as voting, team formation,

fair allocation, and matching. For example, the presenters proposed improvements to the methods with equal shares for committee selection, gave axiomatic characterization of the Hamming and Jaccard Distances, and discussed how to deliver fairly in the *gig economy*. The detailed program is available at <http://mpref2025.mpref.org/m-pref-2025-program-of-preference-handling-workshop.html>.

For more information about future events on preference handling, please consult the website of the *EWG on Preference Handling* <https://www.euro-online.org/web/ewg/31/euro-working-group-on-preference-handling> or subscribe to the newsletter via <https://mpref.org>. 

INTERNATIONAL EXPERTS FROM NUMERICAL ANALYSIS, OPTIMIZATION AND OR MET IN BEAUTIFUL MUSCAT, OMAN, FOR NAOVI-2026

Mehiddin Al-Baali <albaali@squ.edu.om>, Yu-Hong Dai <dyh@lsec.cc.ac.cn>
Anton Purnama <antonp@squ.edu.om>, Sheng-Jie Chen <shengjie_chen@lsec.cc.ac.cn>

The *Sixth International Conference on Numerical Analysis and Optimization: Theory, Algorithms, Applications and Technology (NAOVI-2026)* was successfully held on January 5-8, 2026, at the Department of Mathematics, Sultan Qaboos University (SQU), Muscat, Sultanate of Oman (<https://conferences.squ.edu.om/nao2026/>).

This conference is part of a prestigious series held at SQU once every three years since 2008. Due to COVID-19, the 2023 edition could not be held, making NAOVI-2026 a highly anticipated gathering for the international optimization, numerical analysis, and OR.

NAOVI-2026 was jointly sponsored by SQU, Oman Mathematics Committee (OMC), A Mathematical Programming Language (AMPL) Optimization Inc. (USA),



▲ Participants of NAOVI-2026.

and the Weierstrass Institute for Applied Analysis and Stochastics (WIAS, Germany).>>

>> The Organizing Committee was chaired by *Mohamed Al-Lawati*, with *Mehiddin Al-Baali* and *Anton Purnama* serving as Co-chairs.

The conference featured 21 invited talks and 59 contributed talks, covering recent developments in theory, algorithms, and advanced applications in engineering, science, and medicine. The scientific program included invited talks delivered by distinguished scholars around the world, including Australia (*A.M. Bagirov*), Austria (*P. Markowich*), Belgium (*Ph. Toint*), Canada (*M.Z. Saghir*), China (*Y. Dai*, *X.*

Liu), France (*S. Gratton*), Germany (*M. Hintermüller*), India (*A.K. Pani*), Indonesia (*B. Widodo*), Iran (*N. Mahdavi-Amiri*, *R. Tavakkoli-Moghaddam*), Italy (*F. Guerriero*, *L. Palagi*, *V. Piccialli*, *M.T. Vespucci*), Netherlands (*C. Roos*), Saudi Arabia (*D. Boffi*), Spain (*JM Sanz-Serna*), and USA (*D.M. Gay*, *M. Saunders*).

As with previous editions, selected lectures and contributed papers are expected to be published in the *Springer series on Proceedings in Mathematics and Statistics*, as well as in journals such as *Optimization Methods and Software*, *SQU Journal for Science*, and *Barekeng Journal of Mathematics and its Applications*.

The conference also provided a timely forum to introduce and promote the *Special Interest Group on Optimization (SIG/OPT)*, an initiative under *APORS* (the *Association of Asia-Pacific Operational Research Societies*). Many participants expressed strong interest in *SIG/OPT* and indicated their willingness to become actively involved, including by helping to engage colleagues from countries not yet represented in *IFORS* or *APORS*.

NAOVI-2026 was a great success, reinforcing its reputation as a premier forum for exchanging innovative ideas and fostering international cooperation in numerical analysis, optimization research, and *OR*. 🌐



▲ Some speakers and participants.

ICAISD 2025 STRENGTHENS GLOBAL RESEARCH COLLABORATION IN AI OR CELEBRATED IN JAKARTA, INDONESIA, AND ONLINE

Sumanto <sumanto@bsi.ac.id>, **Agus Junaidi** <agus.asj@bsi.ac.id>, **Dwi Puji Hastuti** <dwi.dsu@bsi.ac.id>, **Riska Aryanti** <riska.rts@bsi.ac.id>, **Retno Rahayuningsih** <retno.rrg@bsi.ac.id>

The *2025 International Conference on Advanced Information Scientific Development (ICAISD)* was successfully held in Jakarta on November 4, 2025, in a hybrid format on the UBSI Kramat 98 Campus, bringing together 190 authors from 8 countries with 49 accepted papers. International delegations included participants from the Philippines, Sweden, Iraq, Bangladesh, Malaysia, India, and Brunei Darussalam. It further solidified its role as a global platform for the exchange of ideas, scientific innovation, and collaborative research.

Carrying the theme “*Artificial Intelligence: Advancing Research and Computational Innovations for Global Welfare*,” *ICAISD 2025* showcased cutting-edge studies and discussions on the role of AI in addressing global challenges and advancing technological development.

The event featured three esteemed keynote speakers: *Prof. Dr. Achmad Nizar Hidayanto* (Universitas Indonesia, Indonesia), *Prof. Dr. Shi-Jinn Horng* (National Taiwan University of

Science and Technology), *Prof. Dr. Gerhard Wilhelm Weber* (Poznan University of Technology, Poland). Several speakers shared practical examples of how *Operations Research (OR)* can improve planning, efficiency, and real-world outcomes. *OR* helped the conference program by offering clear methods to solve difficult problems in decision-making. These contributions showed that *OR* is an important tool for supporting better decisions in many fields.



▲ ICAISD 2025 begins.

Universitas Bina Sarana Informatika organized *ICAISD 2025* with the support of the *IEEE Indonesia Section*, the *IEEE Signal Processing Society Indonesia Section*, and in collaboration with *APTIKOM*, *APTIKOM DKI Jakarta* and several partner universities, including *Universitas Nusa Mandiri*, *Cyber University*, *Universitas Sumatera Utara*, *STIKOM Tunas Bangsa*, *Universitas Raharja*, and *Universitas Teknologi Mataram*. The strong involvement of these institutions reflects a shared commitment to strengthening academic networks and promoting impactful research.

In his official remarks, Conference Chair Assoc. Prof. Dr. Sumanto underscored the importance of sustaining ICAISD as a platform for international scholarly engagement.

"This conference must continue to grow, not only as a space for researchers to share ideas, but also as a driving force to reinforce a strong research culture that is published and recognized at the international level," he said.

ICAISD 2025 reaffirms its mission to foster collaboration, support high-quality scientific publications, and contribute to global technological advancement through continuous research innovation. Further updates can be found on the website: <https://conference.bsi.ac.id/>. 



▲ ICAISD 2025 is collaborating with IEEE.

MIP SOUTH AMERICA 2025 IN VINA DEL MAR, CHILE – AN EVENT ON THE INTERNATIONAL STAGE

Gonzalo Muñoz <gonzalo.m@uchile.cl>

The *Mixed Integer Programming Workshop South America 2025*, held from December 9 to 12, 2025, at the Universidad Adolfo Ibáñez campus in Viña del Mar, Chile, brought together an international community of researchers, students, and industry practitioners for four days of scientific exchange and networking. As the first *MIP workshop* held in *South America*, the event represented an important step in strengthening regional engagement while showcasing state-of-the-art research in mixed-integer programming, discrete optimization and Operational Research (OR) to a global audience. This event was part of the *MIP International Series*, supported by the *Mixed-Integer Programming Society*.



▲ Group photo of celebrated MIP South America 2025.

Organized as a *single-track event*, the workshop featured a carefully curated program combining invited talks, flash talks, and a poster session, together with ample opportunities for informal discussion. With more than *140 participants*, the workshop fostered interaction across career stages and regions, with a particular emphasis on highlighting contributions from South American researchers.

The *Organizing Committee* consisted of Víctor Bucarey (Universidad de O'Higgins, Chile), Margarida Carvalho (Université de Montréal, Canada), Andrés Gómez (University of Southern California, USA), Javier Marengo (Universidad Torcuato Di Tella, Argentina), Gonzalo Muñoz (Universidad de Chile, Chile), and Eduardo Uchoa (Universidade Federal Fluminense, Brazil).

The workshop benefited from the generous support of its sponsors and partners. Primary support was provided by the Department of Industrial Engineering of Universidad de Chile and Hexaly, with additional contributions from Google, the Institute of Engineering Sciences of Universidad

de O'Higgins, Alicanto Labs, the Universidad Adolfo Ibáñez Business School, Cardinal Optimizer, the Institute for Mathematical and Computational Engineering of Pontificia Universidad Católica de Chile, and the Institute for Complex Engineering Systems.

A highlight of the workshop was the *poster session*, which showcased high-quality work by students. *Honorable Mentions* were awarded to Felipe Keim (Universidad de Chile), Domingo Araya (Pontificia Universidad Católica de Chile), Daniel Yamin (Carnegie Mellon University), and Macarena Fredes (Universidad de Santiago de Chile). The *Runner-Up* distinction went to Macarena Navarro (Carnegie Mellon University), and the *MIP Workshop Best Poster Award* was presented to Sebastián Vásquez (Carnegie Mellon University).

Overall, *MIP South America 2025* marked an important milestone for the mixed-integer programming community in the region and laid a strong foundation for future editions of the workshop. 

20 YEARS OF SHAPING FUTURE LEADERS IN DISCRETE MATHEMATICS AND OR – XXI SUMMER SCHOOL 2026 IN VINA DEL MAR, CHILE

Cristóbal Guzmán <crguzman@uc.cl>, **Andrea Jiménez** <andrea.jimenez@uv.cl>, **Pedro Montealegre** <p.montealegre@uai.cl>, **Iván Rapaport** <rapaport@dim.uchile.cl>, **Claudio Telha** <catelha@miuandes.cl>

The *Summer School on Discrete Mathematics*, held annually in Chile since 2006, has become a key event for the Latin American community in Algorithms, Combinatorics, Optimization, Operations Research (OR), and related areas. In recent years, it has also drawn many students from North America and Europe, strengthening its global reach.

The school has evolved significantly. It moved online during the COVID years, and more recently relocated to the *Viña del Mar* campus of *Adolfo Ibañez University*, nearly doubling



▲ Group photo of the XXI Summer School 2026.

attendance. This year, around 80 students and roughly 10 postgraduate participants took part.

As in previous years, we had the privilege this year of hosting three world-renowned researchers with outstanding teaching skills in *Viña del Mar* from January 5th to 9th. Each course comprised five 75-minute lectures, followed by homework assignments for the students.

The *first course*, by *Prof. Shaddin Dughmi* (University of Southern California, USA), was on “*Topics in Decision Making under Uncertainty*”: starting from the classical secretary problem and prophet inequality, the course evolved into online decision-making over more complex combinatorial spaces, particularly some classes of matroids.

The *second course*, by *Prof. Jelani Nelson* (University of California at Berkeley, USA), was on “*Sketching and*

Streaming Algorithms”. Leveraging profound ideas from data structures and randomized algorithms, the course provided both an introduction and some exposure to recent trends in this lively field of research.

The *third course*, by *Prof. Zi-Xia Song* (University of Central Florida, USA), was on the famous “*Hadwiger’s Conjecture*”, a long-standing question in graph theory which contains the celebrated *Four Color Theorem* as a particular case. *Prof. Song* actively engaged with the

students, and encouraged students to conduct research by providing exciting open problems and an in-class working session.

Another innovation at the school for the past few years was that *students* gave *brief talks* on their research. These sessions were scheduled at the end of the day, and showed the large span of topics of interest of the attendants. These presentations may inspire possible topics for future editions at our school.

The school was highly successful: students participated actively, worked diligently on assignments, and prizes for best homework were awarded to *Rory Cordero*, *Luiz Felipe Macedo*, and *Marcelo Machado*. We also warmly acknowledge the *Tas - Javier Marinkovic*, *Juan Pablo Flores*, and *Juan Pablo Peña* - for their essential support. 🌐

WORKSHOP EQUATIONS ARE EVERYWHERE 2025, SUPPORTED BY OR – EXCHANGE AND FRIENDSHIP IN BEAUTIFUL THESSALONIKI, GREECE

Aviv Gibali <avivgi@hit.ac.il>

“*Equations are everywhere*” was the central theme of the mini workshop given by *Prof. Aviv Gibali* from The Holon Institute of Technology, *Holon*, Israel, hosted by the *International Hellenic University in Thessaloniki*, Greece, during December 2025.

This specialized session of the workshop brought together students and faculty to examine the synergy between mathematical theory and *Operational Research (OR)*. The discussion highlighted how quantitative frameworks and optimization models translate theoretical foundations into actionable *decision-support systems* for complex *industrial logistics* and *healthcare resource management*.

The talks covered real-world challenges as well as mathematical riddles such as the 8-queens puzzle and sudoku. The general idea was to introduce the problem, show how it is modelled (mathematical translation) and then derive algorithms for solving the problem by introducing practical concepts such as convergence rate, etc.

Among the problems is the Intensity Modulated Radiation Therapy (IMRT) treatment planning, which aims to deliver a sufficient dose to the tumor while sparing healthy tissue. The problem is modeled using the so-called Split Feasibility Problem.>>

>> Various types of projection methods, simultaneous projections (Cimmino) and sequential successive projections such as POCS (Projections Onto Convex Sets), ART (Algebraic Reconstruction Techniques) or Kaczmarz are described and analysed to solve the problem. Furthermore, examples from Medical Imaging and Signal Processing are presented.



▲ Prof. Aviv Gibali at the Workshop "Equations are Everywhere" 2025, International Hellenic University, Thessaloniki.

This visit to Thessaloniki confirmed the universal language of mathematics. By traversing topics from the geometry of a sunset to the precise algorithms of cancer therapy, the workshop reinforced the conviction that mathematics is not

just a school subject, but a fundamental layer of our reality - or, as the closing remarks put it: "Mathematics is truly everywhere". And so are hospitality and friendship!

The author thanks Erasmus+ KA171 Staff Mobility for its support. 🌐

While the problems mentioned above are mainly convex in nature, an example of non-convex applications in the field of gemstone use is analyzed.

ADDRESSING COMPLEXITY THROUGH OR AND IT – ODSIE 2025 ISTANBUL, TURKEY

A. Mirzazadeh <mirzazadeh@refconf.com>, Zohreh Molamohamadi <scicord@refconf.com>, Erfan Babae Tirkolae <erfan.babae@istinye.edu.tr>, Gerhard-Wilhelm Weber <gerhard.weber@put.poznan.pl>

The 3rd International Conference on Optimization and Data Science in Industrial Engineering 2025 (ODSIE 2025; <https://odsie2025.refconf.com/>) was held online from November 20-22, 2025, hosted in Istanbul, Turkey. The conference gathered researchers and industry experts to exchange insights, practical experiences, and advancements in Operational Research (OR) and Information Technology (IT). Supported scientifically by 18 universities across the globe, ODSIE 2025 highlighted the growing importance of OR and IT in addressing multifaceted challenges and enabling informed, effective decision-making in an increasingly complex global environment.

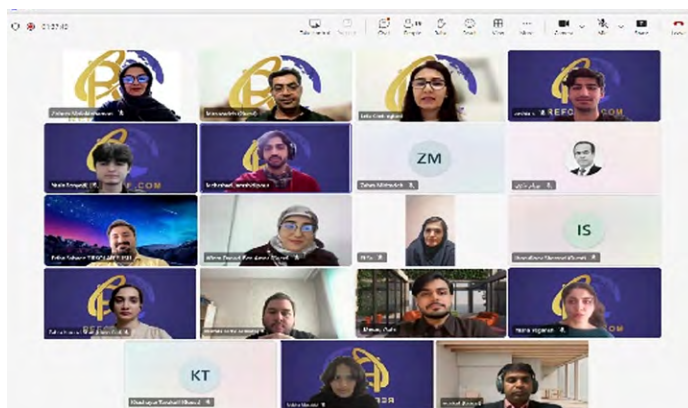

▲ Group photo with some participants.

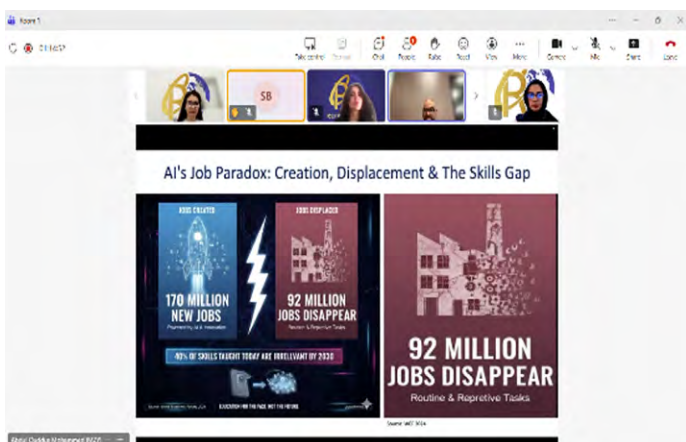

▲ A keynote speech session.

The conference was led by Prof. A. Mirzazadeh and Prof. Erfan Babae Tirkolae as Conference Chairs, with Prof. Gerhard-Wilhelm Weber and Dr. Zohreh Molamohamadi as Technical Program Chairs. Coordination activities were carried out by Ms. Leila Chehreghani, Dr. Zohreh Molamohamadi, Ms. Saina Sahragard, and Ms. Elahe Reeyazati. ODSIE 2025 benefited from significant institutional support from Istinye University (<https://www.istinye.edu.tr/en>) and its leadership team, including Prof. Erkan Ibiş (Rector), Prof. Hatice Gülen (Vice Rector), and Prof. Mehmet Alper Tunga (Dean of the Faculty of Engineering and Natural Sciences).

Representatives from 33 countries contributed to the conference committees, and the scientific program included 20 paper presentation sessions and 8 invited lectures.

Keynote speeches were given by distinguished experts: Dr. Şenol Pişkin (Turkey): "Digital Twins & XR for Translational Healthcare: From Simulation to Clinical Impact", Dr. Abdulquddus Mohammed (UAE): "The Future of Work with AI: Building Human-AI Collaboration Skills", and Dr. Erfan Babae Tirkolae (Turkey): "Towards Waste Management 5.0".

A total of 198 papers were submitted from 28 countries, demonstrating strong international participation. 142 papers were accepted for presentation at the conference. The largest share of submissions came from Turkey (19.93%), followed by Iraq (13.40%), India (12.71%), Ukraine (9.28%), China (8.59%), Bangladesh (7.56%), Iran (4.47%), Oman (3.78%), Algeria (3.44%), the USA (2.41%), and Malaysia (2.06%). Submissions were also received from many other countries and this broad geographical diversity highlights the global reach of ODSIE 2025 and its ability to attract high-quality research from around the world. Selected papers from ODSIE 2025 will be published in Springer CCIS book series (indexed in Scopus, SCImago, EI-Compendex, etc.), and the other papers will be considered for possible publication in peer-reviewed journals. 🌐

MARKETING–DEVELOPMENT–QUALITY CONFERENCE 2025 OR–MS PERSPECTIVES DISCUSSED IN POZNAN, POLAND

Magdalena Graczyk-Kucharska <[magdalena.graczyk-kucharska@put.poznan.pl](mailto:magdalenagraczyk-kucharska@put.poznan.pl)>, Gerhard-Wilhelm Weber <gerhard.weber@put.poznan.pl>



▲ The 70th anniversary of Management Sciences.

Presentations inspired by OR.

Plenary session.

On September 18-19, 2025, the second edition of the international conference “Marketing–Development–Quality” (MDQ) was held at Poznan University of Technology (PUT). Organized by the Faculty of Engineering Management, Department of Marketing and Organizational Development, the event created a vibrant platform linking academia and business through the shared lens of marketing, organizational development, quality, and Operational Research (OR). This year’s edition also celebrated the 70th anniversary of Management Sciences at the University, emphasizing tradition, innovation, and scientific excellence.

Conference Highlights: The program, structured around three thematic tracks - marketing, development, and quality - encouraged interdisciplinary dialogue and integration of quantitative methods in management. The plenary session “Horizons of Development - An Interdisciplinary Perspective on Marketing, Logistics, Economics and Quality” set the stage for exploring how data-driven and human-centered approaches can jointly shape organizational competitiveness.

and publication strategies.

Insights and Key Takeaways: The conference emphasized that modern management requires synergy between marketing insight, operational excellence, and data-supported decisions. Three dominant themes emerged: integration of academic research and business practice through OR-driven evidence; sustainable and responsible development as a foundation of quality management; and human capital and employee engagement as drivers of adaptability and innovation.

Concluding Remarks: MDQ 2025 reaffirmed that competitive advantage in a dynamic environment depends on the ability to combine marketing creativity, organizational development, and quality improvement, supported by the analytical rigor of OR. The organizers announced that the next MDQ Conference will take place on September 17-18, 2026, continuing the mission of connecting science and practice for sustainable management. We also encourage

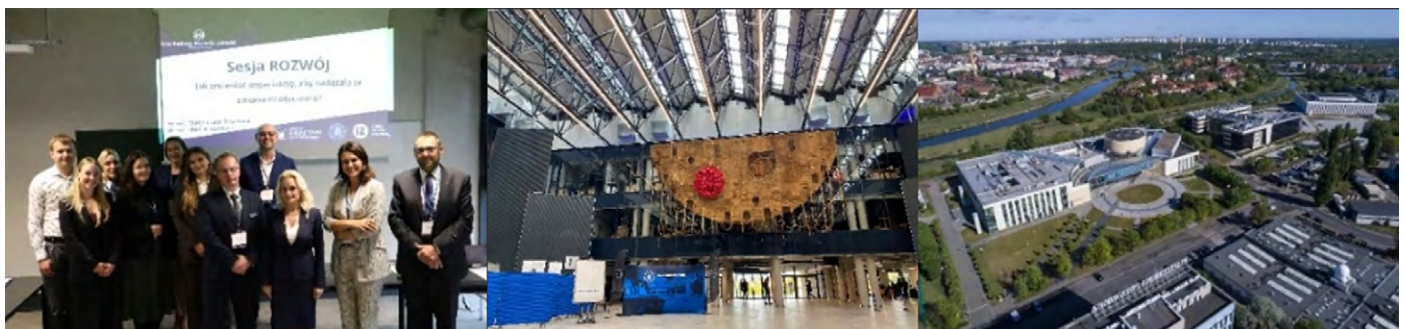

▲ Marketing session.

Faculty of Engineering Management.

PUT Campus, Warta.

In the development and quality tracks, presentations inspired by OR demonstrated the growing role of analytical modeling, optimization, and simulation in management practice. Contributions, including those by Prof. Gerhard-Wilhelm Weber, showcased how OR methods combined with AI, big data, and predictive analytics enhance strategic decision-making, process improvement, and value creation in marketing and organizational contexts.

The marketing sessions focused on transformation and adaptability - exploring how digitalization, innovation, and evidence-based strategies redefine customer engagement and organizational identity. The Paper Development CID Seminar, coordinated by Prof. Dariusz Siemieniako and Prof. Maciej Mitreęga with Dr. Eng. Magdalena Graczyk-Kucharska, provided participants with mentoring in research design

you to follow other upcoming conferences organized at PUT, including the International Conference on Management Science and Engineering Management (ICMSEM) and the European Conference on Knowledge Management (ECKM).

Special thanks go to Prof. Ewa Więcek-Janka for leading the scientific and organizational committees, supported by Dr. Eng. Magdalena Graczyk-Kucharska, Dr. Eng. Marek Goliński, Dr. Eng. Małgorzata Sychała, Dr. Eng. Joanna Majchrzak, and the students of the Engineering Promotion Center at PUT.

Links: <https://konferencjamrj.put.poznan.pl/en/>; [https://www.fem.put.poznan.pl/en?q; https://put.poznan.pl/en; https://www.icmsem.org; https://www.academic-conferences.org/conferences/eckm/](https://www.fem.put.poznan.pl/en?q;https://put.poznan.pl/en;https://www.icmsem.org;https://www.academic-conferences.org/conferences/eckm/). 

THE 34TH JYVASKYLA SUMMER SCHOOL BROUGHT TOGETHER OPTIMIZATION AND DECISION-MAKING ENTHUSIASTS FROM ALL OVER THE WORLD IN FINLAND

Giovanni Misitano <giovanni.a.misitano@jyu.fi>, The Multiobjective Optimization Group <optim@jyu.fi>

The course on “Interactive Multiobjective Optimization: Applications and Tools to Support Decision Making”, organized during the 34th Jyväskylä Summer School in the summer of 2025 in Jyväskylä, Finland, brought together several dozen mostly international participants eager to learn how to apply *interactive multiobjective optimization* to solve a variety of decision-making problems.

The course consisted of five intensive days, each split into lectures given in the morning, followed by a practical session held in computer classes in the afternoon. A variety of topics were covered, including multiobjective optimization problem modeling, scalarization-based and evolutionary interactive methods, visualizations, and group decision-making. The practical application of these was supported by the open-source software framework *DESDEO*. Students were also offered an optional final project to be completed for extra credit. The course was organized by the members of the *Multiobjective Optimization Group*.

In brief, *multiobjective optimization* consists of solving problems with multiple conflicting objective functions to be optimized simultaneously. These problems do not have a single optimum, but instead multiple, so-called *Pareto optimal* solutions exist. When compared, these solutions represent various tradeoffs: we cannot switch from one solution to another in hopes of improving one objective

function without having to sacrifice the value of at least one other function. It is up to a decision maker, a domain expert, to compare Pareto optimal solutions and select the best one. *Interactive methods* incorporate preference information from a decision maker to find the most preferred solutions in an iterative fashion. Interactive methods put the decision maker in a central role, supporting them in learning about the available solutions to the problem and the feasibility of their own preferences.

The course and its materials are available online on the *TIM* platform hosted by the *University of Jyväskylä*. Anybody can access these materials, which offer a solid introduction to the field of interactive multiobjective optimization to individuals with a basic knowledge of optimization. Moreover, the *DESDEO* framework is also freely available for anybody interested in utilizing it for their own endeavors.



▲ Participants and lecturers of the course “Interactive Multiobjective Optimization: Applications and Tools to Support Decision Making”, organized during the 34th Jyväskylä Summer School.

Links:

The course and its materials are available on *TIM* (requires an email address to register): https://tim.jyu.fi/view/kurssitie/interactive_multiobjective_optimization/v/2025/summer/home.

The *DESDEO* software framework is available on GitHub: <https://github.com/industrial-optimization-group/DESDEO>.

The *Multiobjective Optimization Group* at the University of Jyväskylä: <https://optgroup.it.jyu.fi/>.

Cordial thanks to dear **Prof. Kaisa Miettinen** for her communication support that made this report possible. 🌐

LEAHMM 2025 IN NAPLES HEALTHCARE MANAGEMENT – A MULTIDISCIPLINARY PERSPECTIVE, AND OR CONTRIBUTIONS

Giuseppe Converso <giuseppe.converso@unina.it>, Mosè Gallo <mose.gallo@unina.it>

Last October, the 2nd edition of the *International Conference “Logistics and Lean, Engineering in Advanced Healthcare Methodologies Modeling”* was held in Naples, Italy (for details, visit the conference webpage <https://leahmm.com/>). This event, which brought together academic and professional excellence, was dedicated to the application of advanced modeling in logistics and lean manufacturing in the healthcare sector. Initiative and conference itself were shared and cochaired by *Prof. Dr. Gerhard-Wilhelm Weber* (Professor at the Faculty of Engineering Management, Poznan University of Technology), *Prof. Dr. Liberatina C. Santillo* (Full Professor at the Federico II University in Industrial Plants) and *Prof. Dr. Maria Triassi* (Full Professor at the Federico II University Hospital and former Director

of the Department of Integrated Activities of Public Health, Pharmacoutilization and Dermatology, and of the Complex Operating Unit of Hygiene).

The conference served as a key platform for discussion among academics, professionals, and decision-makers in the field, addressing the increasingly complex challenges facing contemporary healthcare management, particularly focused on the combination of optimization issues, *OR*, and *AI*. Notably, this year, the conference was enriched by the invited speech of eminent *Professor Sankar Kumar Roy*, who delineated the current contributions of *OR* to healthcare management and shed light on future trends in an ever-changing context.



▲ Venue of LLEAHMM 2025.

Topics Addressed - Innovation, Processes and Models

LLEAHMM 2025 deeply explored lean production methodologies and logistics as key tools to improve resource management, reduce waste and optimize operational flows in both public and private healthcare facilities. Among the



▲ LLEAHMM 2025 closing ceremony with the OC and eminent guests online.

many relevant topics tackled, the following stood out: Innovative applications of lean processes; Network models

to support decision making; OR for medical logistics management; AI modelling, applied to logistics and lean approach in Healthcare. These topics - which were often interconnected - underlined how the combination of technological and methodological innovation can provide concrete answers to the critical issues that characterize the healthcare sector, such as the increase in demand for services.

Looking Ahead

The conference laid the foundation for a new era of research and applications in healthcare management. Participants shared the need for an interdisciplinary approach, where logistics experts, engineers, medical doctors, and healthcare professionals work together to design sustainable and innovative solutions. Because of the success of previous editions, the long-term aim of LLEAHMM is to build an international network of experts and promote the dissemination of best practices in the sector. In this spirit, future editions of LLEAHMM should not only be a scientific event, but also a moment of encounter, sharing and inspiration, capable of stimulating a real change in healthcare. 🌐

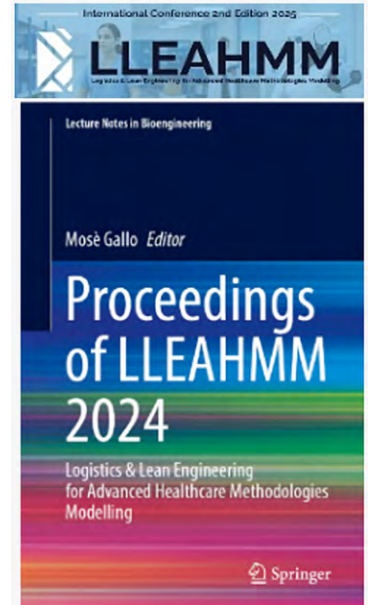

▲ Logo and Book of LLEAHMM 2024.

51ST LNMB CONFERENCE 2026 – THE DUTCH NETWORK ON THE MATHEMATICS OF OPERATIONS RESEARCH

Maria Vlasidou <lnmb@utwente.nl>

The *Dutch Network on the Mathematics of Operations Research, LNMB*, is an interuniversity cooperation in the Netherlands since 1987 and plays a central role in the *Operations Research* community by promoting close collaboration that regularly leads to results with substantial societal impact. LNMB is responsible for the national graduate education in OR, offering a broad and coherent programme of advanced OR courses. In 2026, the network awarded the 398th LNMB Diploma, underlining the continued growth and vitality of the Dutch OR community.

The annual LNMB conference, “*The Mathematics of Operations Research*”, is the premier gathering in the Netherlands for senior and junior researchers working in OR. The 51st edition took place in Soesterberg on 12-14 January 2026. It brought together more than 210 participants from universities, research institutes, industry, and the public sector from across the country and abroad, confirming the upward trend and visibility of OR in the Netherlands.

The programme featured presentations on high-quality research and real-world applications, showcasing the

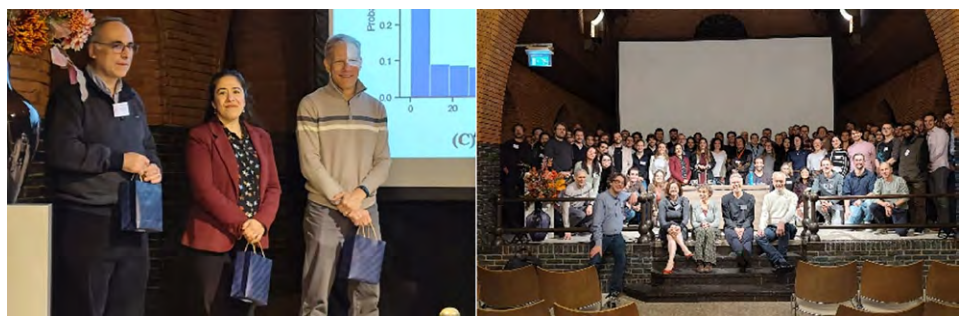

▲ Snapshots from LNMB 2026: the keynote speakers (left), and impression of the participants (right).

breadth of contemporary OR. The keynote talks of the 2026 LNMB Conference were delivered by Merve Bodur (University of Edinburgh), Antonis Economou (National and Kapodistrian University of Athens), Matthew O. Jackson (Stanford University), and Madeleine Udell (Stanford University). A distinctive feature of the conference is the emphasis on the work of PhD candidates. The 2026 PhD sessions offered an overview of ongoing research across all national OR groups, with talks spanning combinatorial optimisation, stochastic OR, game theory, supply chain management, and emerging topics at the interface of OR and machine learning. This broad coverage helps maintain an integrated national community and offers early-career researchers the opportunity to receive feedback from peers and senior experts in a rigorous setting.

The third day of the 2026 LNMB Conference focused on the timely theme “Generative AI and Operations Research.” This day brought together leading experts from academia and industry to explore how recent advances in generative AI are shaping OR. The speakers included *Durk Kingma* (Anthropic), *Wouter Kool* (ORTEC), *Bernardino Romera Paredes* (Hiverge) and *Madeleine Udell* (Stanford University),

who discussed the intersection of AI and OR from both methodological and application-oriented perspectives. The programme also featured an interactive session and a dedicated networking lunch for PhD students with representatives from industry, further strengthening ties between research and practice.

Prof. Dr. Maria Vlassiou, University of Twente, is the LNMB Director. 

GLOBAL TRIZ EXPERTS FROM INVENTIVE PROBLEM SOLVING DISCUSSED AI – TRAI 2025 PARIS RECOGNIZED THE IMPORTANCE OF OR

Joanna Majchrzak <joanna.majchrzak@put.poznan.pl>, **Denis Cavallucci** <denis.cavallucci@insa-strasbourg.fr>, **Gerhard-Wilhelm Weber** <gerhard.weber@put.poznan.pl>

The ongoing convergence of *Artificial Intelligence (AI)* and the *Theory of Inventive Problem Solving (TRIZ)* is redefining the landscape of scientific and technological innovation. Recent advances, such as the use of AI in scientific discovery, enable breakthroughs that were previously unimaginable, accelerating the pace of innovation in many areas of science and life.



▲ Selected participants of TRAI 2025 Paris.

TRAI 2025, organized by the *International Society for Artificial Intelligence powered Invention and Innovation (ISAIII)*, *European TRIZ Association (ETRIA)*, *International Federation for Information Processing (IFIP)* and *INSA Graduate School of Engineering of Strasbourg*, was held on November 5-7, 2025, in Paris-Saclay, France (<https://trai2025.org>). It aimed to serve as a global platform to explore the various synergies, foster interdisciplinary collaborations, and address the ethical, societal, and technological challenges associated with these advancements.

The Organizing Committee included the General Chair *Prof. Denis Cavallucci* (ICube, INSA Strasbourg, France), the Scientific Co-Chairs *Prof. Stelian Brad* (Technical University of Cluj-Napoca, Romania) and *Prof. Pavel Livotov* (PPI, Offenburg University, Germany), and the members *Dr. Rémy Houssin*, *Dr. Hicham Chibane*, *Dr. Amadou Coulibaly* (ICube, INSA Strasbourg, France), *Laurent Lelait* and *Gilles Rougon* (EDF, France), who contributed to the success of TRAI 2025.

The main objectives of TRAI 2025 were to integrate AI

and TRIZ, accelerate scientific discoveries and implement mathematical modelling and *Operational Research (OR)* into the selected concepts of Inventive Problem Solving, to explore further scientific, ethical, practical and societal aspects, and to create an environment for new interdisciplinary collaboration.

The conference program included 5 keynote speeches, and 45 other presentations on research results, classified into 18 parallel sessions. *Best Papers Awards* were assigned to works such as “*Enhancing AI-Generated Solutions With Visual Retrieval-Augmented Generation (V-RAG): A Framework for Problem Formulation*” (Mas’udah et al., 2025) and “*Investigating the Integration and Adaptation of ARIZ With Large Language Models*” (Ayaou et al., 2025).

All studies discussed at the conference are published in book volumes “*World Conference of AI-Powered Innovation and TRIZ Methodology - 2nd IFIP WG 5.4*”, Springer, *International TRIZ Future Conference, TRAI 2025, Paris, France, November 5-7, 2025, Proceedings, Part I and Part II*. 

THE 2ND EDITION OF OR@AFRICA DAY 2025 IN ALGIERS, ALGERIA – A FIRST STEP TOWARD A TRAVELING OPERATIONS RESEARCH INITIATIVE IN AFRICA

<contact@oratafrica.org>

Wissem Ahmed Zaid <wissemahmedzaid@gmail.com>, **Mohamed Faouzi Benammour** <benammour.m.f@gmail.com>

OR@Africa organized the second edition of *OR@Africa Day* on December 4, 2025, in Algiers, Algeria, marking a significant milestone for the initiative and a first concrete step on African soil. Hosted at the *Université des Sciences et de la Technologie Houari Boumedién*, this edition allowed OR@Africa to directly engage with young Operations Research students and researchers within an African

academic environment. The successful organization of this event was made possible through a strong collaboration with *Operations Research Society Club*, a student-led initiative. This collaboration highlights the essential role played by student engagement in promoting operations research and fostering academic dynamism within African universities.



▲ Participants of the 2nd edition of OR@Africa Day.

Conference Highlights: Three Scientific Sessions

The conference was structured around three complementary sessions, designed to showcase the diversity of operations research communities, topics, and geographical backgrounds. The **first session** focused on local academic expertise, with professors based in Algeria

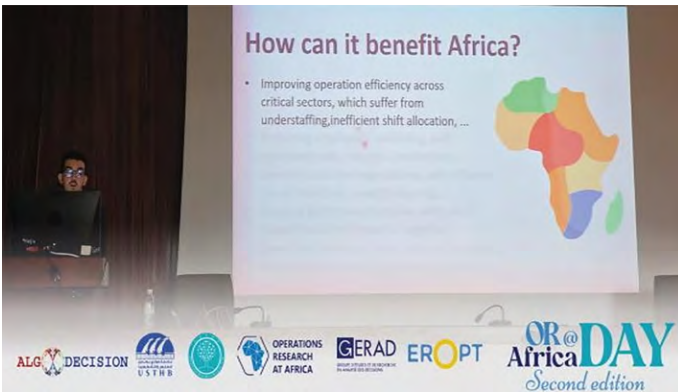

▲ Talk on OR@Africa Day.

presenting research addressing national and regional challenges. The **second and third sessions** adopted a hybrid format, bringing together young researchers, doctoral students, and established academics from different countries.

Contributions came from *Prof. Ali Ridha Mahjoub* (Kuwait University), *Lounes Bentaha*, *Latifa Belhocine*, *Khaled Khayati*, *Youssef Hadhbi* (France), *Pawoumodom Takouda* (Canada), and *Syphax Ait Oubelli* (Algeria), illustrating the richness of perspectives and the global reach of the OR@Africa community.

The event was supported by *ALGODECISION*, an Operations Research company engaged in collaborations in Africa, and by *GERAD*, a Canadian research center in *Operations Research*. The scientific organization of the event was further supported and supervised by *OR@Africa* advisors, *Professors Issmail El Hallaoui*, *Youssef Diouane*, *Walid Klibi*, and *Gerhard Wilhelm Weber*.

A Vision for a Traveling OR@Africa Day

OR@Africa aims to develop *OR@Africa* Day as a travelling event across Africa, bringing operations research to new universities and communities each year. The *OR@Africa* Day marked an important step toward this vision and laid the foundations for future editions. For more details about the event, visit our LinkedIn page: <https://www.linkedin.com/company/oratafrica>



BOOK REVIEW

Section Editors:

Jinal Parikh <jinal.parikh@ahduni.edu.in>

Gerhard-Wilhelm Weber <gerhard.weber@put.poznan.pl>



INTERVAL LINEAR PROGRAMMING AND EXTENSIONS

by **Milan Hladik**

Springer Optimization and Its Applications,
 ISBN ISBN 978-3-031-85095-0, ISBN ISBN 978-3-031-85096-7 (eBook)
<https://doi.org/10.1007/978-3-031-85096-7>

OR-ANALYTICS THROUGH INTERVAL LINEAR PROGRAMMING

Jinal Parikh <jinal.parikh@ahduni.edu.in>

Gerhard-Wilhelm Weber <gerhard.weber@put.poznan.pl>

This book, *“Interval Linear Programming and Extensions”* by *Milan Hladik*, stemmed from the observation that, despite the substantial body of literature on interval-valued programming, no comprehensive monograph has presented the subject and its results in a coherent and unified manner as yet. Essentially, it depicts how interval programming involves solving mathematical programming problems with interval data, which may represent uncertainty arising from multiple sources viz. - measurement or numerical

errors, missing values, discretization errors, linearization of non-linear functions, etc. While it is based on the ideology that the fundamental principle of interval analysis is to account for all possible realizations of interval data, it assumes that the true values in interval analysis lie within a known interval, regardless of the source of uncertainty. While the title of this book has been meticulously chosen to pay homage to *Dantzig’s* pioneering 1963 work on linear programming, >>

>> it has been modestly adopted with the hope that the volume will stimulate further research into the theory, methodologies, and applications of interval-valued programming.

“Interval Linear Programming and Extensions” examines real-valued linear programming problems while investigating the impact of allowing selected coefficients to vary within prescribed intervals. The primary goal is to analyze how, and to what extent, such variations influence the optimal solution and the optimal value, or whether the problem retains its stability. In addition, the book addresses a range of other closely related theoretical and methodological issues. The book is organized into three parts.

The **first part** introduces interval analysis and computation, covering the fundamentals of intervals, interval vectors and matrices, and their operations, with particular emphasis on linear systems of equations and inequalities with interval coefficients. It also addresses solution concepts, solvability conditions, algorithmic approaches, and computational complexity, laying the groundwork for interval linear programming.

The **second part** focuses on linear programming with interval data, examining how variations in coefficients influence optimal values, optimal solutions, stability properties (such as optimal bases), and duality. While the general framework allows all coefficients to be interval-valued, special attention is given to practically relevant cases where intervals appear in the objective function or right-hand side. Special LP models, including transportation problems, and a wide range of applications are also discussed.

The third part explores extensions of interval linear programming, including interval multi-objective programming and selected nonlinear problems such as convex quadratic and linear fractional programming. It further considers generalizations of interval representations through quantified intervals and extensions to more general uncertainty sets, including transformed boxes and convex polyhedra.

This book is versatile and has been skilfully written to suit the tastes of both the general audience who have the basic mathematical knowledge acquired along with their secondary education, as well as a specific audience who require an additional background in mathematics for a full understanding of certain sections and paragraphs in it. The author has thoughtfully incorporated the first chapter, which provides elementary knowledge about linear algebra, linear programming, non-linear programming, and computational complexity, so as to streamline the understanding of the readers. The authors have made an arduous attempt to provide examples and comments that make the material clear and approachable. The book is largely self-contained, with almost all results rigorously proved; only a few technically involved proofs are omitted, in which cases suitable references are provided.

The book is composed of 16 chapters, each featuring an extensive understanding of the topic covered in that specific chapter. The author has also provided an exhaustive list of references and an index of the topics covered in the concluding part of the book.

A brief overview of the highlights of the chapters in this

book follows:

Chapter 1 – “Preliminaries” reviews the fundamental concepts, definitions, and results that form the foundation of the book. These include selected topics from elementary linear algebra, calculus, linear and nonlinear programming, and computational complexity.

Chapter 2 – “Introduction” begins with motivating the reader by illustrating the natural occurrence of interval data across diverse fields. Next, it introduces the fundamental concepts, notation, and objects—intervals, interval vectors, and interval matrices—used throughout the book. It further presents basic interval arithmetic and its properties, along with introductory enclosure techniques for evaluating functions over intervals.

Chapter 3 – “Interval Systems of Linear Equations” focuses on interval systems of linear equations, a foundational topic in interval computation and interval linear programming. It introduces the concept of (weak) solutions, characterizes the solution set and its geometric properties, discusses computational complexity, and presents enclosure as well as exact solution methods. The chapter also examines the regularity of interval matrices as a closely related issue.

Chapter 4 – “General Interval Linear Systems” examines linear systems with interval coefficients, beginning with inequalities and extending to mixed systems of equations and inequalities. It introduces weak and strong solvability concepts, characterizes their solution sets and geometric properties, and analyzes the associated computational complexity.

Chapter 5 – “Introduction to Interval Linear Programming” introduces interval linear programming and outlines the scope of the topic covered in this part of the book. It presents the basic models, including primal and dual formulations, and highlights key issues such as the impact of data variability on optimal values, solutions, feasibility, boundedness, and duality, illustrated through selected examples.

Chapter 6 – “Optimal value range” studies how variations in LP coefficients within prescribed intervals affect the optimal value. It examines the computation of best- and worst-case optimal values, analyzes the continuity and overall structure of the set of achievable optimal values, and discusses computational complexity. Given the intractability of exact computations in many cases, the chapter also presents approximation methods.

Chapter 7 – “Basis Stability” focuses on basis stability in interval linear programming, where a single basis remains optimal for all realizations of the interval data. Such stability enables efficient computation of optimal values and solution sets. Although verifying basis stability is co-NP-hard, the chapter presents interval-based sufficient conditions that can be used in practice.

Chapter 8 – “Optimal solution set” examines the optimal solution set arising from all realizations of an interval LP problem, highlighting its fundamental complexity and the absence of a simple characterization. It therefore emphasizes approximation through inner and outer estimation methods, presents algorithms for membership testing despite NP-hardness, and discusses the boundedness of optimal solutions for individual LP realizations.

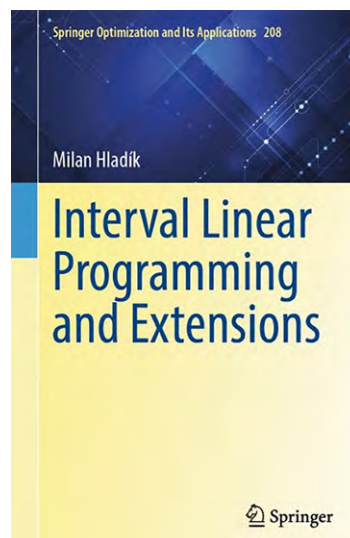

▲ *OR-Analytics through Interval Linear Programming.*

Chapter 9 – “Other issues” addresses additional topics in interval linear programming beyond optimal values and solutions. It studies duality and conditions for a zero duality gap, examines the effects of common LP transformations under interval data, and analyzes boundedness, optimality across realizations, worst-case optimal values, and constraint redundancy.

Chapter 10 – “Special Interval cases” focuses on interval linear programming problems where only the objective function, the right-hand side, or both contain interval coefficients, while the constraint matrix is fixed. In these cases, many challenging issues - such as computing optimal values and solutions, assessing basis stability, and analyzing boundedness - become more tractable.

Chapter 11 – “Special LP cases” examines special structured LP problems commonly arising in practice, focusing on the transportation problem, network flow problems, and the shortest path problem. It emphasizes the analysis of the optimal value function, where stronger results can be obtained compared with general interval LPs.

Chapter 12 – “Applications” explores applications of interval linear programming across various areas, including game theory, multi-criteria decision-making, linear regression, and robust optimization. It also demonstrates how interval methods can aid real-valued problems through techniques such as numerical verification of optimality, sensitivity analysis using the tolerance approach, and the construction of LP condition numbers.

Chapter 13 – “Interval Multiobjective Linear Programming” studies multiobjective LP problems with interval-valued objectives and fixed constraints, introducing the concepts of necessary and possible efficiency (holding for all or at least one realization, respectively). It characterizes these notions, discusses their properties and computational complexity, and applies interval methods to sensitivity analysis in real-valued problems using the tolerance approach to determine cost coefficient ranges that preserve solution efficiency.

Chapter 14 – “Nonlinear Programming Problems with Interval

Data” focuses on nonlinear programming problems with interval data, emphasizing the computation of the range of optimal values. It presents a general framework for determining best- and worst-case optimal values and applies it to specific problem classes—such as convex quadratic, posynomial geometric, linear fractional, linear bilevel, and linear complementarity problems—where deeper analysis often yields stronger results than general methods.

Chapter 15 – “AE Interval Linear Programming” extends the treatment of interval parameters by introducing $\forall\exists$ -quantification, a generalization of universal and existential cases. It first examines $\forall\exists$ -quantified interval systems of linear equations and inequalities, analyzing their solutions and solvability, and then applies the concept to $\forall\exists$ -quantified LP problems, proposing two approaches based on robust optimization.

Chapter 16 – “General Parameter and Enclosing Sets” explores generalized interval LP models where coefficients are not independent. It addresses linear dependencies between interval coefficients and considers more general uncertainty sets, such as polytopes and ellipsoids, using advanced enclosures like zonotopes and other polyhedral representations.

While this book provides a strong foundation in interval linear programming, it also points to several exciting directions for future research and practice.

Opportunities include advances in uncertainty modelling through hybrid and regulatory systems across *OR-MS* and its interfaces with finance, engineering, environmental, behavioral, and space(-time) sciences. In particular, extensions to option pricing, portfolio optimization, risk management, and robust stochastic control and games - incorporating features such as regime switching, memory, and delay - offer significant potential.

These developments can further strengthen the role of *OR* in addressing complex decision-making challenges in the world we live in. 🌐

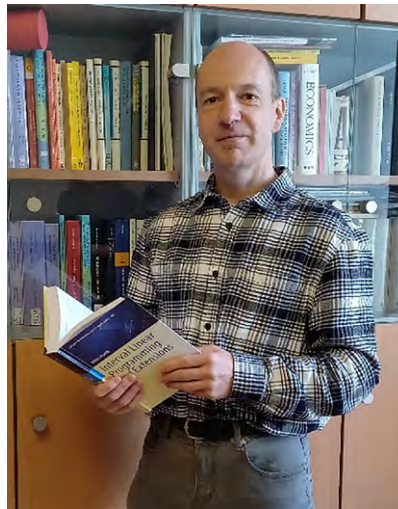

▲ Book author: Professor Milan Hladik.

IFORS NEWS

Editor in Chief: Sibel Alumur Alev

Regional Correspondents	
ALIO	José-Fernando Camacho-Vallejo
APORS	Yukun Cheng
EURO	Gerhard Wilhelm Weber, Sarah Fores
NORAM	Sibel Alumur Alev

Section Editors	
OR Impact	John Ranyard John Medhurst
Tutorial	James Cochran
Conferences	Gerhard Wilhelm Weber Jinal Parikh
Book Review	Jinal Parikh Gerhard Wilhelm Weber

Country Correspondents	
Argentina	Javier Marengo
Australia	Hasan H. Turan
Austria	Margaretha Gansterer
Belarus	Boris Rozin
Belgium	Dimitri Papadimitriou
Brazil	Maristela Silva
Canada	Majid Taghavi

Chile	Armin Lüer
China	Yukun Cheng
Colombia	Juan Guillermo Villegas Ramirez
Croatia	Snjezana Pivac
Czech Republic	Jaroslav Ramik
Denmark	Sanne Wohlk
Estonia	Peep Miidla
Finland	Olli Herrala
France	Olivier Peton
Germany	Karlin Eisele
Greece	Yannis Politis
Hong Kong	Yong-Hong Kuo
Hungary	Zoltán Süle
Iceland	Eyjolfur Ingi Asgeirsson
India	Samarjit Kar
Indonesia	Diah Chaerani
Iran	Nezam Mahdavi-Amiri
Ireland	Cathal Brugha
Israel	Michal Tzur
Japan	Takamori Ukai
Korea	Bumsoo Kim
Lithuania	Leonidas Sakalauskas
Malaysia	Wan Nor Munirah Ariffin

Mexico	Cynthia De la Cruz-Marquez
Nepal	Sunity Shrestha Hada
Netherlands	LCM Kallenberg
New Zealand	Andy Philpott
Nigeria	Folahan Owolabi
Norway	Torkel Haufmann
Peru	Alicia Riojas Canari
Philippines	Elise A. Del Rosario
Poland	Jan W. Owsinski
Portugal	Tânia Rodrigues Pereira Ramos
Singapore	Tan Kok Choon
Slovakia	Zuzana Čičková
Slovenia	Lidija Zadnik Stirn
South Africa	Dave Evans
Spain	Carlos Villanueva
Sweden	Jan Kronqvist
Switzerland	Christiane Barz
Tunisia	Hela Moalla Frikha
Türkiye	Cem Iyigun
UK	Sarah Davies
USA	Jim Cochran
Uruguay	Carlos Testuri